

5 Reasons Why Reed Relays are Ideal for Semiconductor Testing

Exploring the Ideal Switch Technology: The Benefits of Reed Relays in Wafer Probe Stations

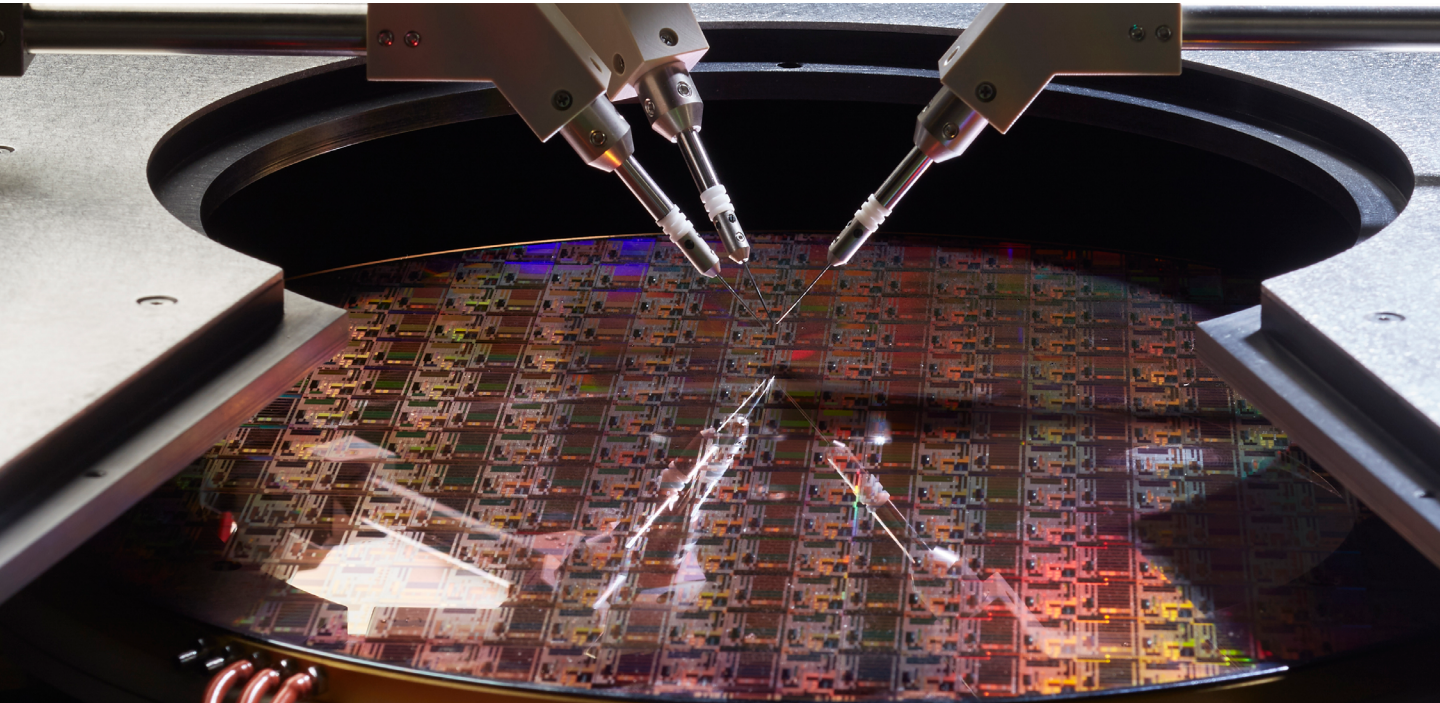

In this application guide:

- Semiconductor Testing
- Switching Technologies
- Reed Relay Terminology
- Recommended Products
- Why Pickering Electronics for Reed Relays?

Once a semiconductor wafer is fabricated, but before it is 'sliced and diced' into the dies that will be packed into components, it is subjected to wafer probe testing. The tests are performed by wafer probing machines, a type of automatic testing equipment (ATE) that is used to verify the functionality of the individual dies, be they relatively simple structures such as diodes and transistors or more complex integrated circuits such as processors, microcontrollers, memory, and analog to digital converters.

The probes are moved around the wafer to connect with pads on the surface of the individual die and to apply test conditions (voltages, currents, or waveforms, for example) that the ATE supplies and to measure voltage levels, current flow, output waveforms, for example that the ATE needs to record.

Semiconductor test methods include DC parametric testing (at different levels of current and voltage) and AC parametric testing (at different frequencies) – both to ensure the device meets the required specifications – and functional testing to ensure that it operates as intended. For power semiconductor devices it is necessary to apply and record high voltages and for high frequency / radio frequency (HF/RF) devices it is necessary to apply and record appropriate waveforms.

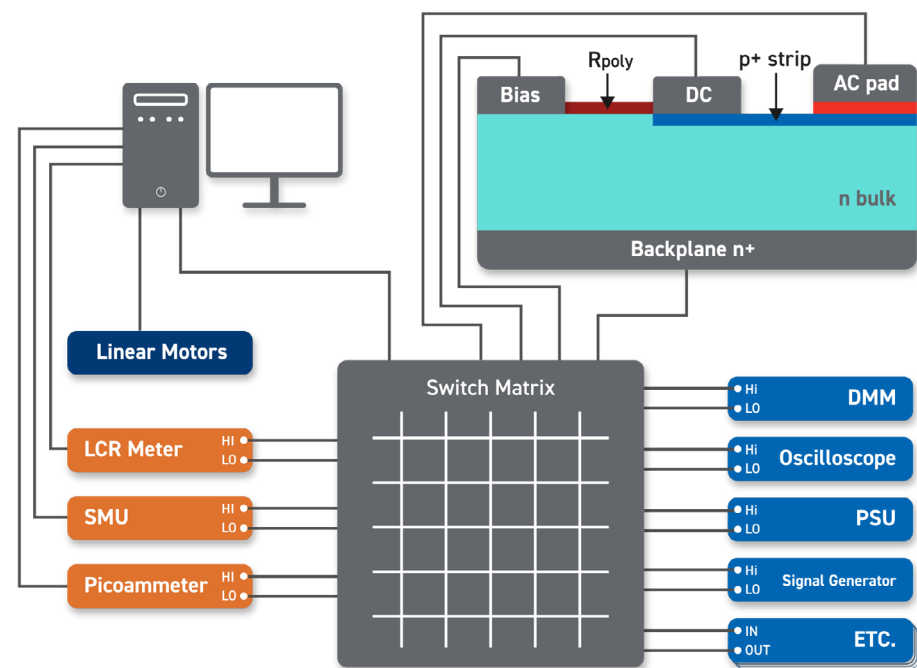

Diagram 1 Above, an example of a testing configuration.

All of this means the ATE must be capable of applying a variety of test conditions. However, the probe station may have only a few probes (just two is fairly standard), so the ATE needs to be able to switch between multiple test conditions and channel the test results into the appropriate signal conditioning circuitry. And this is where reed relays, as controllable switching devices, prove invaluable - and for five reasons:

1. Transparency

They do not appear as an inline load, so do not alter the test condition or skew results. Specifically, reed relays have a low ON and a high OFF resistance, they provide high isolation, and boast low leakage current.

2. Performance

They can switch a few kV and can be used to measure down to a few μV . They can also operate at high speed. For example, devices in the Pickering Series 124 have been shown (through tests) to have operating times in the range of 80 to 90 μs . In addition, reed relays can be used to apply pulsed carry currents (i.e., higher than their continuous max carry current ratings).

3. Form factor

Most semiconductor test ATE systems will require dozens of switching devices, so space is at a premium. Though not smaller than solid-state or MEMS devices (which do not possess the 'transparency' described above, by the way), reed relays are much smaller than electromechanical relays (EMRs). Note: Pickering devices can be placed very close together thanks to internal EM shielding (see later), meaning less PCB real estate is needed.

4. Reliability

Used within their intended operating parameters, reed relays can provide billions of operations, maintaining high performance and reliability throughout.

5. Overall cost-effectiveness

The long-term reliability of a reed relay plays a crucial role. When a device is highly reliable, it has an extended service life, reducing the need for frequent replacements, if they are even required at all for most applications. This significantly minimizes the chances of unexpected failures, thereby reducing equipment downtime for maintenance or repair. The total cost of ownership (TCO) is therefore an important consideration, as selecting less reliable devices is a false economy.

Given the considerable expense associated with the fabrication of a semiconductor wafer, great emphasis is placed on quality assurance, and confirming that each die functions correctly before it is sliced, diced, and packaged. Also, as the switching technology within a wafer probe system is one of the most crucial aspects - providing that essential connection between the wafer and the ATE - opting for reed relays is a sensible choice as they are unobtrusive, efficient, and cost-effective.

When choosing a reed relay for a semiconductor test application, the following are the most crucial factors to consider:

- **Maximum Switching Power.** The product of the voltage and current being switched must not exceed this value.
- **Maximum Switching Voltage.** The highest DC or AC (peak) voltage that can be switched.
- **Minimum Standoff Voltage.** The minimum DC or AC (peak) voltage that can be applied across the open contacts before breakdown occurs. For high-voltage applications, the higher the minimum standoff voltage the better, as it improves safety and reliability.
- **Maximum Switching Current.** The maximum current the contacts can switch within the constraints of the contact power rating. Note: be mindful of switching (on) to highly capacitive loads and when removing power from highly inductive loads.
- **Maximum Carry Current.** The highest continuous current the device can pass through the closed contacts. Current pulses can be employed to achieve significantly higher levels, depending on the duty cycle.
- **Coil Voltage.** The nominal DC operating voltage of the relay coil.
- **Coil Resistance.** The nominal resistance of the operating coil, usually specified at 25°C.
- **Insulation Resistance.** This is the resistance between any of the device pins. This needs to be very high (ideally greater than 1TΩ (Tera Ohms, so 1×10^{12} Ohms) if you are to keep current leakage to a minimum.
- **External Shield Clearance.** Some devices (typically low-cost) have an external metal shield to protect against EM interference from neighboring relays. If the screen extends to the relay base, or is too close to the base, this can cause problems when placed on a PCB carrying high voltages. However, the clearance might not even be stated on the datasheet, and you may need to refer to technical drawings or measure the clearance on a sample device. Note: the relays we recommend below all have internal shielding in the form of mu-metal screens around their coils.

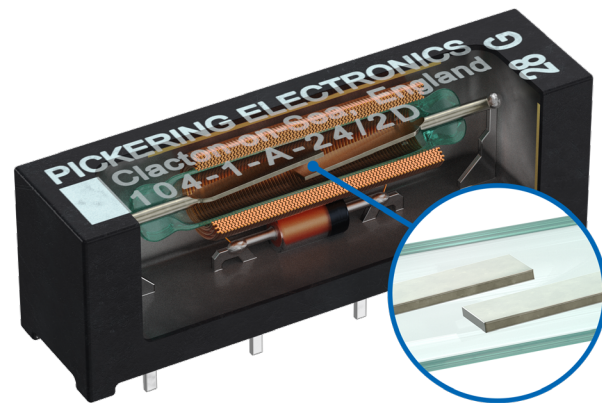

For high-voltage reed relays, the contact is sealed in a vacuum, greatly increasing the minimum standoff and maximum switching voltages. Insulation resistance is high thanks to pin spacing and the relay's base material. As for external shield clearance, this is not an issue when the EM shielding is on the inside of the device.

By considering these key factors, you can make a well-informed decision when selecting the appropriate reed relay for your medical application. Other information you will need to consider when designing your medical equipment includes contact configuration and service life.

Contact Configuration (Forms)

Form A	Form B	Form C
<p>Common ○ — De-energized</p> <p>Common ○ — Energized</p>	<p>Common ○ — De-energized</p> <p>Common ○ — Energized</p>	<p>Common ○ — De-energized</p> <p>Common ○ — Normally Closed</p> <p>Common ○ — Normally Open</p> <p>Common ○ — Energized</p> <p>Common ○ — Normally Closed</p> <p>Common ○ — Normally Open</p>
<p>With the coil de-energized the switch is normally open (NO). If just one switch is present, the form is 1A, meaning single pole single throw normally open (SPST-NO). If two switches are present, the form is 2A, meaning double pole single throw normally open (DPST-NO). With three switches it is 3A (3PST-NO).</p>	<p>With the coil de-energized the switch is normally closed (NC). If just one switch is present, the form is 1B, meaning single pole single throw normally closed (SPST-NC). If two switches are present, the form is 2B, meaning double pole single throw normally closed (DPST-NC). With three switches it is 3B (3PST-NC).</p>	<p>These are changeover devices that break their NC contact (and close the NO one) when the coil is energized. If just one switch is present, the form is 1C, meaning single pole, double throw (SPDT). If two switches are present, the form is 2C DPDT. With three switches it is 3C.</p>

What's the Service Life?



This is the one figure on any datasheet, from any manufacturer, that is open to interpretation. We state 1×10^9 operations for most applications, but the fact of the matter is the figure could be higher or lower depending on the exact application. Considerations are: How close to voltage and current limits are you operating? What is the switching duty cycle? Are you likely to see inrush currents?

Also, at what point do you consider the device to be failing? When contact resistance increases by 10%? 20%? More?

Rest Assured, We're Here to Help

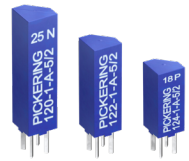
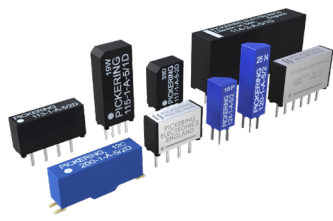
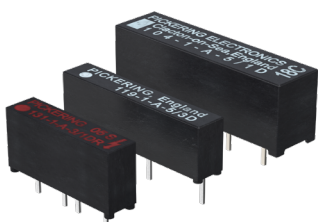
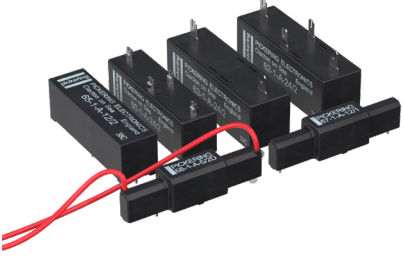
Tell us about your application and we'll not only recommend the most suitable device, but we'll also give you an indication of the device's realistic service life.

RECOMMENDED PRODUCTS	
<p>Pickering Electronics has an extensive range of high-performance, high voltage isolation reed relays that are ideally suited to use in semiconductor testing applications. Furthermore, with device footprints starting at just 16 mm², many relays can be accommodated on a single PCB. We particularly recommend the following series.</p>	
Ultra-High Density Reed Relays	High Density Relays
 <p>These relays have a maximum switch current of 1A (up to 20W), and the maximum carry current is 1.2A. Fast operate and release times (as low as 80µs or less) make these relays suitable for high-speed test systems.</p> <p>Body dimensions from (W x H x D): 3.9 x 9.5 x 3.9mm. Available forms: 1 Form A contact configuration.</p>	 <p>These relays have a maximum switch current of 1A (up to 20W), and the maximum carry current is 1.2A. Switches feature sputtered ruthenium contacts for long life and high reliability.</p> <p>Body dimensions from (W x H x D): 6.6 x 9.5 x 3.7mm. Available forms: 1 Form A, 1 Form A Coax, 2 Form A, 1 Form B, and 1 Form C contact configurations.</p>
Miniature High-Voltage Reed Relays	High-Voltage Reed Relays
 <p>These relays have switching voltages up to 1.5kV and standoff voltages up to 5kV. The maximum switch current is 1A (up to 25W) and the maximum carry current is 1.5A. High coil resistance options (up to 6.8kΩ). Thermal EMF devices are between 3 and 10µV. Relays can endure temperatures as high as 150°C if requested.</p> <p>Body dimensions from (W x H x D): 12.5 x 6.6 x 3.7mm. Available forms: 1 Form A, 2 Form A, and 1 Form B contact configurations.</p>	 <p>These relays have switching voltages up to 12.5kV and minimum standoff voltages up to 15kV. The maximum switch current is 3A (up to 200W) and the maximum carry current is up to 5A. Option of PCB pins, chassis, PCB mounting, and flying leads.</p> <p>Body dimensions from (W x H x D): 58.4 x 19.0 x 12.6mm. Available forms: 1 Form A, 1 Form B, and 1 Form C contact configurations.</p>

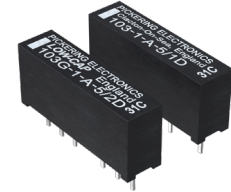
RECOMMENDED PRODUCTS	
High Coil Resistance Reed Relays	Low Thermal EMF Reed Relays
 <p>These relays have a maximum switch current of 1A (up to 20W), and the maximum carry current is 1.2A. Fast operate and release times (as low as 80µs or less) make these relays suitable for high-speed test systems.</p> <p>Body dimensions from (W x H x D): 3.9 x 9.5 x 3.9mm. Available forms: 1 Form A contact configuration.</p>	 <p>These relays have a maximum switch current of 1A (up to 20W), and the maximum carry current is 1.2A. Switches feature sputtered ruthenium contacts for long life and high reliability.</p> <p>Body dimensions from (W x H x D): 6.6 x 9.5 x 3.7mm. Available forms: 1 Form A, 1 Form A Coax, 2 Form A, 1 Form B, and 1 Form C contact configurations.</p>
Industry Standard Size Reed Relays	Low Capacitance Reed Relays
 <p>These relays have a maximum switch current of 1A (up to 20W), and the maximum carry current is 1.2A. Featuring superb contact resistance stability and ultra-high insulation resistance.</p> <p>Body dimensions from (W x H x D): 19.1 x 7.6 x 4.8mm. Available forms: 1 Form A, 2 Form A, 1 Form B, 1 Form C, and 2 Form C contact configurations.</p>	 <p>These relays have switching voltages up to 12.5kV and minimum standoff voltages up to 15kV. The maximum switch current is 3A (up to 200W) and the maximum carry current is up to 5A. Option of PCB pins, chassis, PCB mounting, and flying leads.</p> <p>Body dimensions from (W x H x D): 58.4 x 19.0 x 12.6mm. Available forms: 1 Form A, 1 Form B, and 1 Form C contact configurations.</p>

RECOMMENDED PRODUCTS

Coaxial Reed Relays

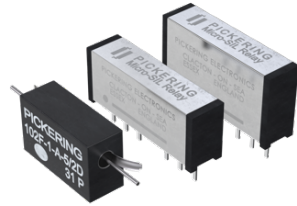

These relays have a maximum switch current of **1A** (up to **20W**), and the maximum carry current is **1.2A**. Devices with **50 and 75Ω** coils are suitable for up to **5GHz**, making them ideal for RF Signal Switching, RF switched tunable filters, and High-Speed Digital Switching.

Available in **thru-hole** and **SMT**.

Body dimensions from (W x H x D): 12.5 x 6.6 x 3.7mm.

Available forms: **1 Form A** and **1 Form B**

Why Pickering Electronics for Reed Relays?

- ✓ We've been making reed relays since 1968. It's our core business and has laid the foundation for the switching and simulation division of Pickering Group, **Pickering Interfaces**.
- ✓ The relays recommended in this guide are all instrumentation grade and the reed contacts will be plated with either Rhodium (electro-plated) or Ruthenium (vacuum spluttered) to ensure a long life – typically up to 5x10⁹ operations.
- ✓ They are of a **formerless coil construction**, which increases the coil winding volume, maximizes the magnetic efficiency, and allows for the use of less sensitive reed switches, resulting in optimal switching action and **extended lifetime** at operational extremes.
- ✓ Internal mu-metal magnetic screening enables **ultra-high PCB side-by-side packing densities** with minimal magnetic interaction, **saving significant cost and space**. Our magnetic screen reduces EM interaction to approximately 5%. Low quality relays typically exhibit an EM interaction of 30%.
- ✓ **SoftCenter™** technology provides maximum cushioned protection of the reed switch, minimizing internal lifetime stresses and **extending the working life and contact stability**.
- ✓ Inspection at every stage of manufacturing **maintaining high levels of quality**. Also, **100% testing** for all operating parameters including dynamic contact wave-shape analysis with full data scrutiny to maintain consistency. Stress testing of the manufacturing processes, from -20°C to +85°C to -20°C, repeated 3 times.

While we have recommended a variety of our standard relays, each with performance characteristics and properties that make them ideal for specific medical equipment applications, we have over a thousand catalogue parts; so, there are plenty to choose from.

However, if you cannot find a product that meets your exact requirements, we offer a full customization service.



We have a well-proven development lifecycle of: Agree requirements, design, manufacture, test, approve, and deliver. And if your custom design is based on one of our existing products (which is likely to be the case) you can expect to receive samples in as few as two weeks.

For further information, contact our technical sales team at: techsales@pickeringrelay.com

About Pickering Electronics

Pickering Electronics was established over 50 years ago to design and manufacture high quality reed relays, intended principally for use in instrumentation and test equipment. Today, Pickering's Single-in-Line package (SIL/SIP) range is by far the most developed in the relay industry, with devices 25% the size of our competitors' electrically equivalent devices. These small SIL/SIP reed relays are sold in high volumes to large ATE and semiconductor companies throughout the world.

The privately-owned Pickering Group comprises three electronics manufacturers: reed relay company Pickering Electronics; Pickering Interfaces, designers and manufacturers of modular signal switching and simulation products, and Pickering Connect, which designs and manufactures cables and connectors. The group employs over 500 people primarily in the UK and Czech Republic with additional employees in sales offices in the US, China, Germany, Sweden, and France.

Technical Help

Please go to: pickeringrelay.com/help.

If your questions are not answered here, please e-mail: techsales@pickeringrelay.com.

Alternatively, please call our Technical Sales Office on **+44 (0)1255 428141**.

Pickering Electronics Ltd. Tel: +44 1255 428141
 Stephenson Road email: techsales@pickeringrelay.com
 Clacton-on-Sea Web: pickeringrelay.com
 C015 4NL
 United Kingdom

Registered in England no. 857509 VAT no GB103 5366 04
 Registered Office: Stephenson Rd, Clacton-on-Sea, Essex. C015 4NL



Copyright (2024) Pickering Electronics Ltd. All Rights Reserved. Pickering Electronics maintains a commitment to continuous product development, consequently we reserve the right to vary from the descriptions given in this booklet. Cover image ©SemiProbe