

ALL DESIGN, OPERATIVE AND PROCESS DATA PERTAINING TO THE ARTICLE SHOWN ON THIS SHEET IS THE PROPERTY OF POLYPHASER CORPORATION. THE INFORMATION IS NOT TO BE COPIED, REPRODUCED, REVEALED TO OR APPROPRIATED BY OTHERS WITHOUT THE EXPRESS WRITTEN CONSENT OF POLYPHASER CORPORATION.

REVISIONS

REV LTR	DATE	ENG	MKTG	Q.A.

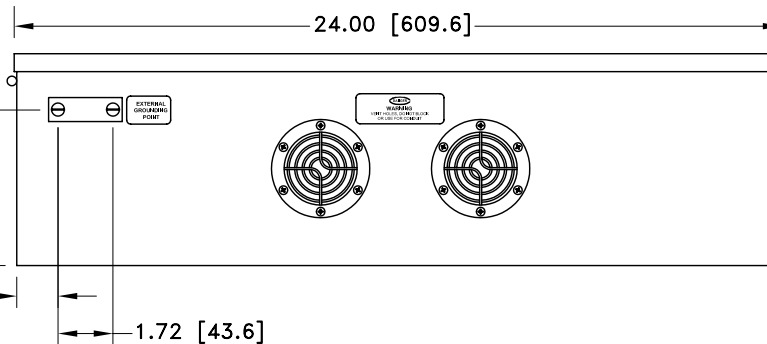
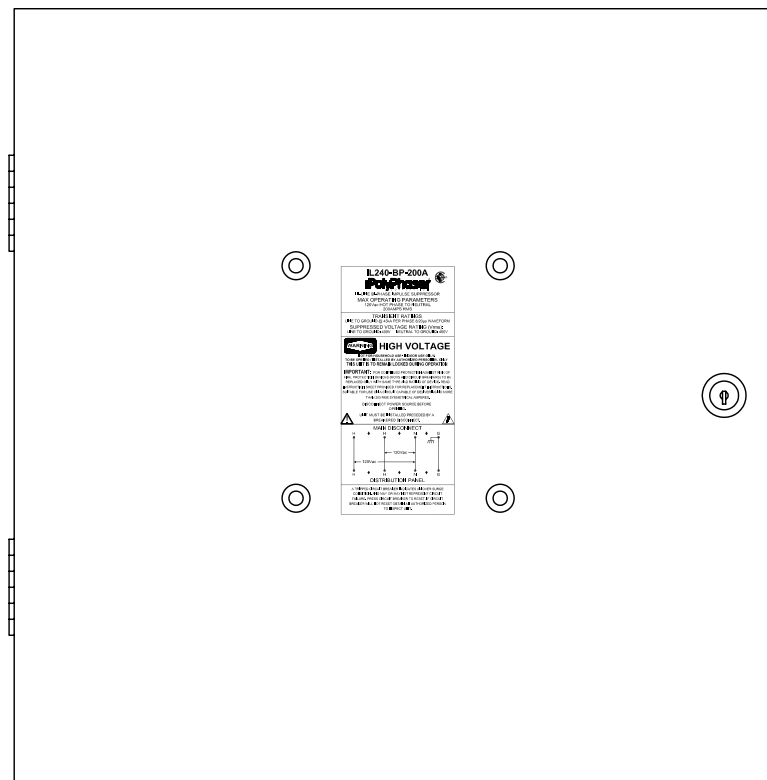
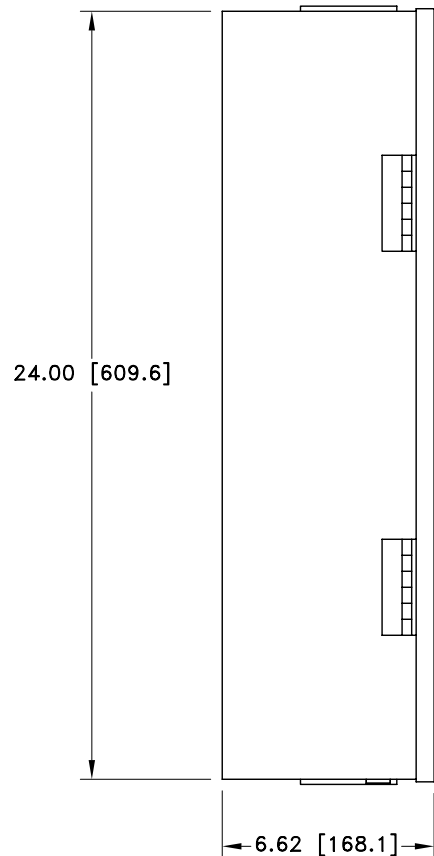

CUSTOMER APPROVAL: _____ DATE: _____

ALL DIMENSIONS SHOWN ABOVE ARE FOR REFERENCE ONLY.

DRAFTER S. HALL	DATE 12/02/03	 P.O. BOX 9000 MINDEN, NV 89423 TEL: 775-782-2511 FAX: 775-782-4476 IL240-BP-200A CUSTOMER PRINT	
MECH ENGINEER R. DUNNING	DATE 12/02/03		
ELEC ENGINEER J. JONES	DATE 12/02/03		
MARKETING S. DOTTER	DATE 12/02/03		
QUALITY DEPT L. JACQUES	DATE 12/02/03		
CAGE CODE 61114	FILE NAME -C1	SCALE 1/6	SHEET 1 OF 1