

| Part Number | Relay Description |
|-------------|---|
| C61 | Solid-State Relay with Terminals for Through-Hole Mount |
| SC61 | Solid-State Relay with Terminals for Surface Mount |

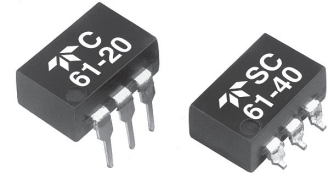

ELECTRICAL SPECIFICATIONS

(25°C UNLESS OTHERWISE SPECIFIED)

INPUT (CONTROL) SPECIFICATIONS

| Parameter | Min | Max | Units |
|--------------------------------|-----|-----|-------|
| Input Voltage Drop @ 10mA | 1.1 | 1.5 | Vdc |
| Input Current | 5 | 50 | mA |
| Reverse Voltage Protection | | -6 | Vdc |
| Input Current (Guaranteed off) | | 100 | µA |
| Input Current (Guaranteed on) | 5 | | mA |

OUTPUT (LOAD) SPECIFICATIONS

| Parameter | Min | Max | Units |
|---|-----------------|------|------------------|
| Load Voltage Rating | C61-20 | 100 | Vdc |
| | C61-40 | 400 | |
| Output Current (See Figure 2) | C61-20 | 1.0 | A _{dc} |
| | C61-40 | 0.4 | |
| On Resistance (See Note 7) | C61-20 | 0.3 | Ohm |
| | C61-40 | 2.0 | |
| Turn-On Time (See Figure 4 and Note 2) | C61-20 | 3.0 | ms |
| | C61-40 | 3.0 | |
| Turn-Off Time | C61-20 | 3.0 | ms |
| | C61-40 | 3.0 | |
| Output Capacitance | C61-20 | 250 | pF |
| | C61-40 | 200 | |
| Leakage Current at Rated Voltage | | 1.0 | µA _{dc} |
| Dielectric Strength | | 1500 | V _{rms} |
| Input to Output Isolation | 10 ⁹ | | Ohms |
| Junction Temperature (T _J) | | 125 | °C |
| Junction to Ambient Thermal Resistance | | 150 | °C/W |

FEATURES/BENEFITS

- Optical Isolation: Isolates control elements from load transients. Eliminates ground loops and signal ground noise.
- Low On Resistance power FET Output: Low leakage and voltage drop.
- Switches High Voltages and Currents: Voltages to 400 Vdc; Currents to 1.0 A_{dc}
- Floating Output: Allows for high and low side switching
- High Noise Immunity: Control circuit can not be triggered by output switching noise.
- 6-Pin Mini DIP Package: Through-hole or surface-mount available

DESCRIPTION

The Series C61 solid-state relay is an advanced design capable of switching heavy loads in a physically small 6 pin mini-DIP package. These relays have a power FET output that ensures low On Resistance, and low leakage current.

Optical isolation ensures complete protection of signal lines, power and ground bus and control circuits from switching noise and EMI.

BLOCK DIAGRAM

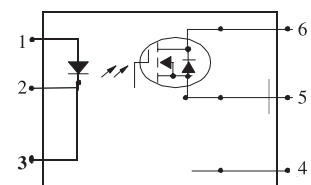

CHARACTERISTIC CURVES

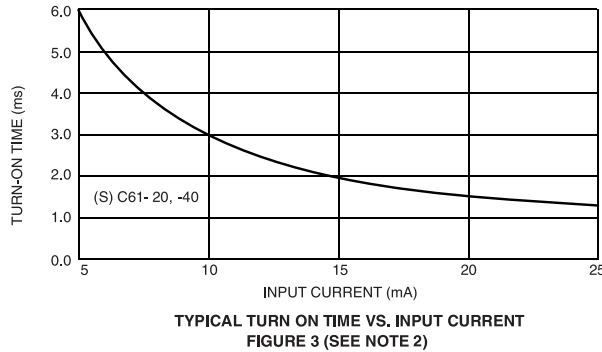
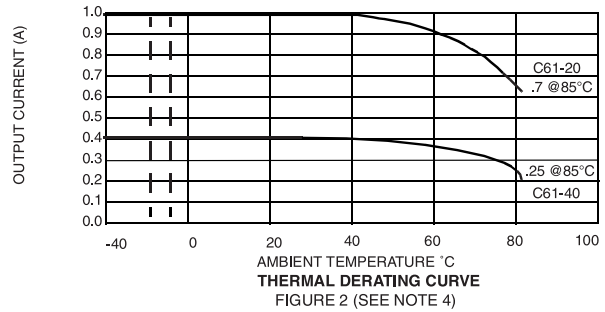
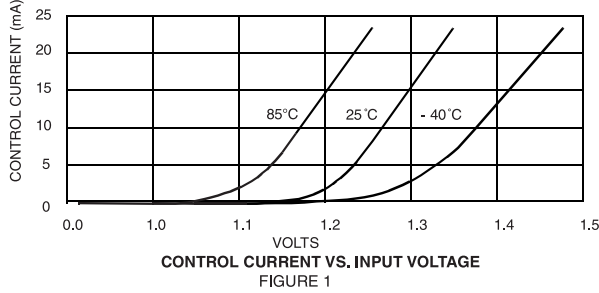

MECHANICAL SPECIFICATION

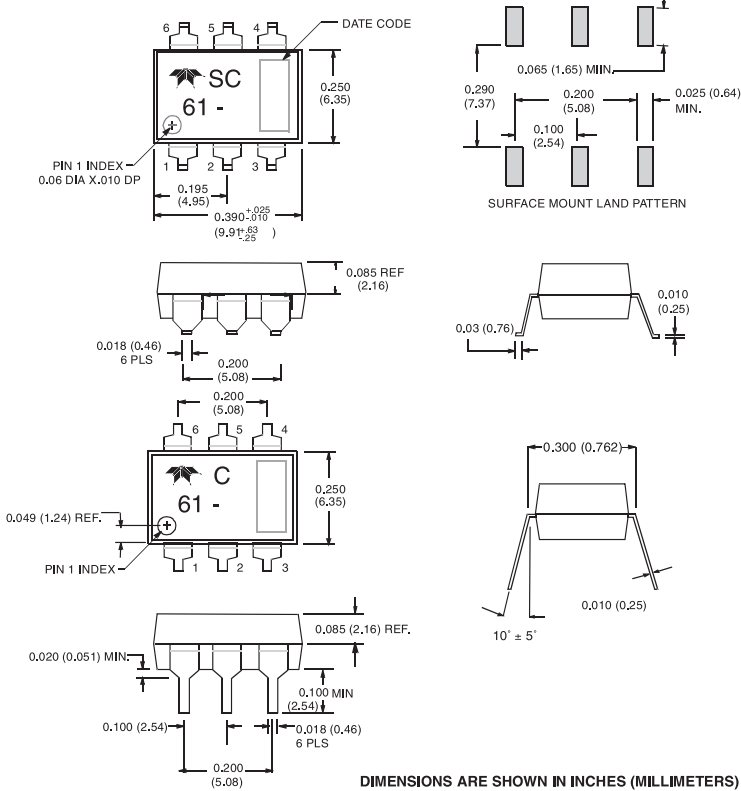

± Operating Temperature Range: -40°C to 85°C
± Storage Temperature Range: -40°C to 100°C
± Weight: 1 gm. maximum
± Case: 6 pin dual In line, filled epoxy.

WIRING CONFIGURATIONS

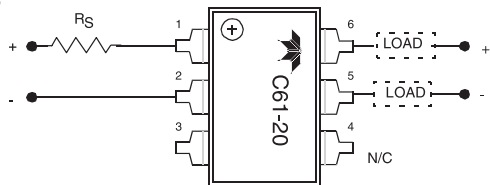

NOTES:

- Series resistor is required to limit input current to 50 mA maximum.
- Turn On Time can be controlled with input control current. Calculate a new turn-on-time: $t_{ON} = (t_{\text{Specification Limit}}) \cdot (I_{10\text{mA}} / I_{IN})$
- The input current is 10 mA for all tests unless otherwise specified.
- Continuous load current is rated under the conditions of still air and mounted on a printed circuit board.
- Loads may be connected to positive or negative referenced power supplies. Inductive loads must be diode suppressed.
- The surge current is non-repetitive for a maximum duration of 20 ms (See Figure 3).
- To calculate maximum ON Resistance for a given junction temperature calculate the new R_{ON} using the equation shown below:

$$R_{ON} = R_{(25^\circ\text{C})} \times e^{0.006 (T_J - 25^\circ\text{C})}$$