

FCA-410 Series, 10 Amperes, 4PDT



Product Facts

- Hermetically Sealed
- All Welded Construction
- Balanced Force
- Permanent Magnet Drive
- 4PDT switching in one inch cube
- Contacts — Silver Cadmium Oxide with Gold Plating
- Coils for DC and AC 50 to 400Hz or 400Hz
- Weight 2.72 ounces max. (77 grams max.)
- Qualified to M83536/15, /16

The Series FCA-410 relay is a polarized single-side stable design, where the flux from a permanent magnet provides the armature holding force in the deactivated state, and its flux path is switched and combined with the coil flux in the operated state. This results in appreciably increased contact pressure in both states over that of a spring return nonpolar

design. We also manufacture 2-pole and 6-pole versions of this relay.

FCA-210 — 10 Amp DPDT Relay

FCA-610 — 10 Amp 6PDT Relay

Available

FCA-415 — 15 Amp 4PDT, Has the same specifications as the FCA-410 except is rated at 15 amps. (Commercial Only)

Contact Rating — Amperes Ratings Are Continuous Duty

Type of Load	Life (Min.) Cycles x 10 ³	28 VDC	120VAC 400Hz	120/200VAC	
				400Hz-3Ø	60Hz-3Ø*
Resistive	100	10	10	10	2.5
Inductive	20	8	8	8	2.5
Motor	100	4	4	4	2.0
Lamp	100	2	2	2	1.0

*60 Hz loads rated for 10,000 operations

Overload Current — 40 AMPS DC, 60 AMPS 400Hz

Rupture Current — 50 AMPS DC, 80 AMPS 400Hz

Contact Make Bounce — 1 MILLISECOND AT NOMINAL VOLTAGE

Max. Contact Drop at 10 Amps — INITIAL 0.100 VOLTS

End of Life — 0.125 VOLTS

General Specifications

Temperature Rating — -70°C TO +125°C

Altitude — 300,000 Feet

Shock* —

Z & Y Enclosures —

200 g for 6 ms

W, X & M Enclosures —

100 g for 6 ms

Vibration, Sinusoidal* —

Z & Y Enclosures —

0.12 DA 10 to 70Hz

30 g 70 to 3000Hz

W, X & M Enclosures —

0.12 DA 10 to 57Hz

20 g 57 to 3000Hz

Vibration, Random* —

Z & Y Enclosures —

0.4 g²/Hz 50-2000Hz

W, X & M Enclosures —

0.2 g²/Hz 50-2000Hz

Dielectric Strength —

At Sea Level —

All circuits to ground and circuit to circuit — 1250 V rms

Coil to ground — 1000 V rms

At 80,000 Feet — 350 V rms

Insulation Resistance —

Initial (500 VDC) — 100 MΩ Min.

After Life or Environmental Tests —

50 MΩ Min.

Operate Time at Nominal Voltage —

DC Relays — 15 ms or less

AC Relays — 20 ms or less

Release Time at Nominal Voltage —

DC Relays — 15 ms or less

AC Relays — 50 ms or less

* Max. contact opening under vibration or shock 10 microseconds

Coil Data

Coil Code	Nominal Voltages	Freq. Hz	DC Res. AC Amps (B)	Over Temperature Range		
				Pickup or Below Volts	Dropout or Above Volts	Must Hold Voltage (C)
1	6	DC	18 Ω	4.5	0.3	2.5
2	12	DC	70 Ω	9.0	0.75	4.5
3	28	DC	290 Ω	18.0	1.5	7.0
4 (A)	28	DC	290 Ω	18.0	1.5	7.0
5	48	DC	865 Ω	32.0	2.5	14.0
6	28	400Hz	225 mA	22.0	1.25	10.0
7	28	50/400Hz	120 mA	22.0	1.25	10.0
8	115	400 Hz	40 mA	90.0	5.0	40.0
9	115	50/400 Hz	30 mA	95.0	5.0	40.0

A. CODE 4 COILS HAVE BACK EMF SUPPRESSION TO 42 VOLTS MAX.

B. DC COIL RESISTANCE ± 10% AT 25°C; AC COIL MAX. CURRENT AT NOMINAL VOLTAGE.

C. RELAY WILL STAY IN PICKED-UP STATE DOWN TO MUST HOLD VOLTAGES SHOWN.

D. MAX. OVER-VOLTAGE: 6 & 12 VDC COILS 120% OF NOMINAL; ALL OTHERS 110% OF NOMINAL.

E. COILS AVAILABLE FOR OTHER VOLTAGES AND FOR AC 50/60HZ.

NOTE: Only DC Coil Models are QPL Approved.

FCA-410 Series, 10 Amperes, 4PDT (Continued)

Below are shown the standard terminal types and the enclosures available. Note that the pin configuration for coil connections is determined by the coil supply voltage. Specify the assembly as indicated under How To Order. Dimensions are shown in inches ± .010 and (Millimeters ± .25) except as noted.

Terminals

Terminals on 0.200 centers.
Coil terminals: X1-X2.
Socket Pins are Gold Plated.
Circuit Board Pins are Tin/Lead Plated.

CODE "A"
Socket Pins-All DC Coils

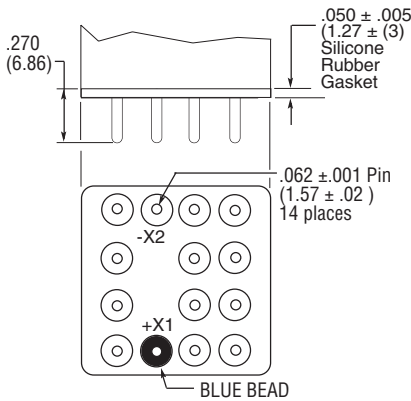

CODE "B"
Circuit Board Pins-All DC Coils

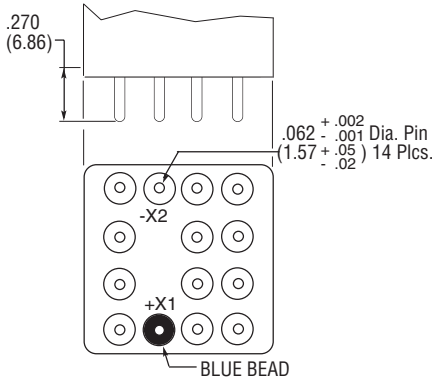

CODE "C"
Solder Hooks-AC or DC Coils

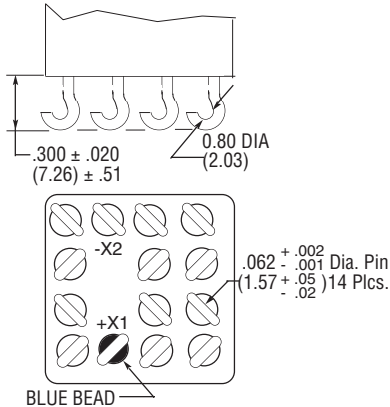

CODE "D"

Socket Pins-115 VAC Coils

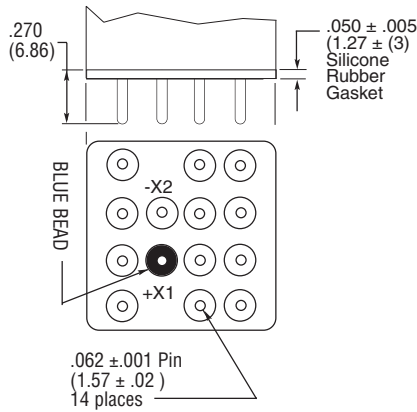

Enclosures

All Enclosures have cupro-Nickel cans bright acid tin/lead plated after assembly to terminal headers.

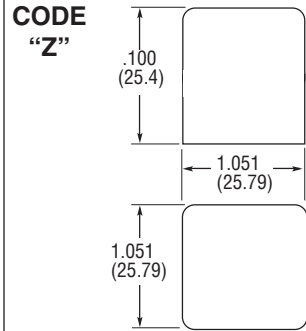

CODE

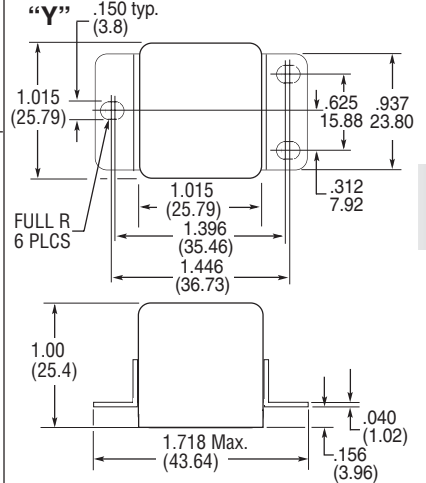

**SEE NEXT PAGE
FOR MORE COIL
TERMINAL OPTIONS**

CODE

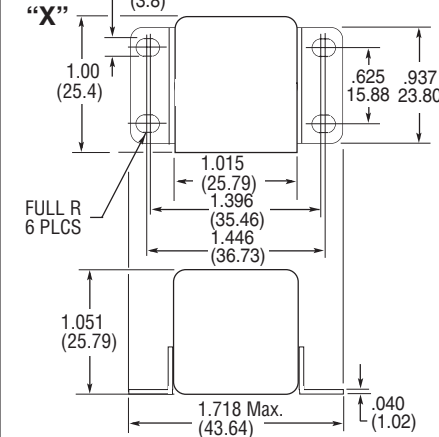

CODE

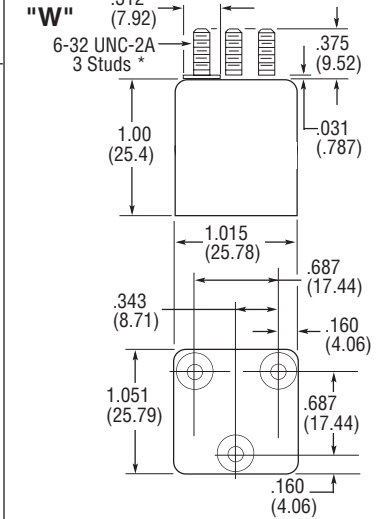

*Metric threads available. To specify use [M] in place of [W]

5
CII Mid-Range Relays

FCA-410 Series, 10 Amperes, 4PDT (Continued)

Terminals (Continued)

CODE "E"

Socket Pins- 28 VAC Coils

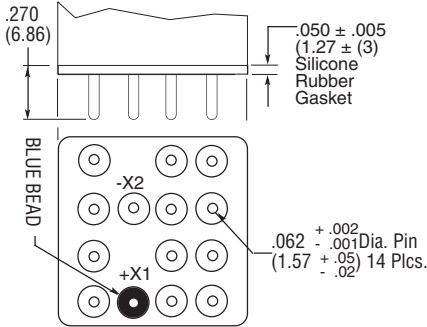

CODE "F"

Circuit Board Pins-115 VAC Coils

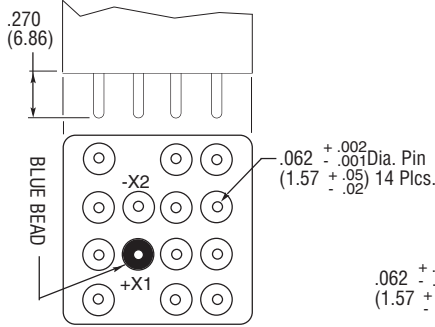

CODE "G"

Circuit Board Pins- 28 VAC Coils

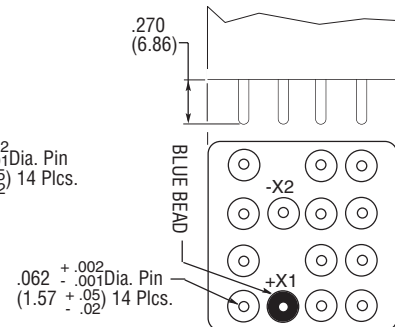

Terminal Wiring

A & B Pin Terminal All DC Coils

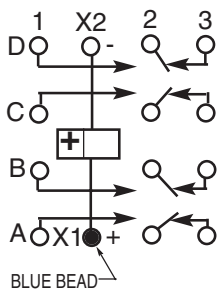

C Hook Terminal All AC & DC Coils

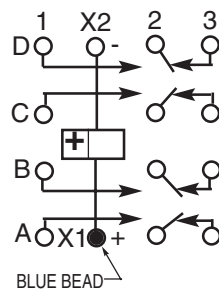

Transient Suppression Cir.

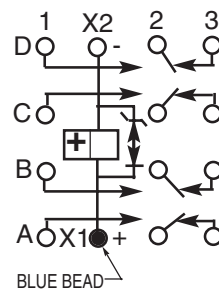

D & F Pin Terminal 115 VAC Coils

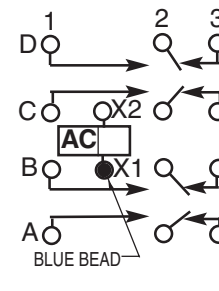

E & G Pin Terminal 28 VAC Coils

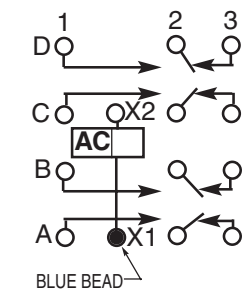

NOTE: Polarity must be observed with DC coil supply. Relay is polarized with a permanent magnet and will not operate or be damaged by reverse polarity.

Diodes used in transient suppression and in AC rectifier circuits have peak inverse voltage rating of 600 VDC minimum. Zener diodes have a minimum rating of 1 watt.

Terminal designations are for reference only and do not appear on the header.

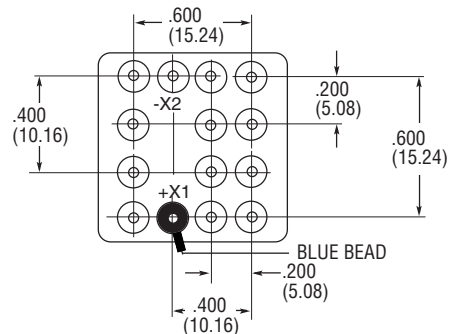

TERMINAL VIEW

**FCA-415-
FCA-410 A Y 4**

HOW TO ORDER

RELAY TYPE _____

TERMINALS (Socket Pins) _____

ENCLOSURE (With Flanges) _____

COIL (28 VDC With Transient Suppression). _____

NOTE: Only DC coil models are QPL Approved

* The part number example shown on this page is for catalog items. For a list of specific QPL part numbers, please see the index in Section 15.