

Data Sheet

Customer: _____

Product: High Voltage Ceramic Disc Capacitor _____

Type : K _____

Issued Date : 01-Feb.-2023 _____

Edition: Ver. 2 _____

Record of change

Date	Ver.	Description	Page
30-Dec.-2016	1		
01-Feb.-2023	2	Revised Part No.	

HITANO ENTERPRISE CORP.

7F-7, No. 3, Wu Chuan 1st Road, New Taipei Industrial Park,

New Taipei City, TAIWAN, R.O.C.

Tel: +886 2 2299 1331 (Rep.)

Fax: +886 2 2298 2466, 2298 2969

Prepared by	Checked by	Approved by	Accepted by (customer)
01-Feb.-2023	01-Feb.-2023	01-Feb.-2023	
Hwa Wu	Andy Hsu	Arthur Su	

SPECIFICATION

1. Operating temperature range: -25°C~+85°C
2. Rated working voltage: 2KV to 15KV
3. Capacitance: Within tolerance for Class I at 1MHz / Class II at 1 KHz, 1 to 3Vrms, 25°C
4. Test voltage: 2KV & above: 2 times rated voltage , 3 ~ 5KV: 1.75 times,
6 ~ 15KV: 1.5 times. 50mA max charging current for 1 ~ 5 seconds.
5. Dissipation factor/Q factor:

Class I: 1MHz, 1 TO 3Vrms, 25°C	Class II: 1KHz, 1 TO 3Vrms, 25°C
C≤30PF..... Q≥400+20C	Y5P, Z5U..... 2.5% Max
C>30PF..... Q≥ 1,000	Z5V 5% Max
6. Insulation Resistance: 10,000 MΩ or 200 MΩ.μF, whichever is smaller.
7. Humidity test: Per EIA RS198-C, Method B3, Condition B. ΔC/C: 30% Max for Z5V, 20% Max for others.
8. Life test: Per EIA RS198-C, Method C2, Condition C at 85±2°C and 200% rated working voltage.
ΔC/C: 30% Max for Z5V, 20% Max for others.. DF: 5% max for Z5V, 3% Max for others. I.R.: 10,000 MΩ Min.

Part No. Designation

Example	K	P	6K3	221	K	-	L	0	1	8	B	D	11.5
	(1)	(2)	(3)	(4)	(5)		(6)	(7)	(8)	(9)	(10)	(11)	(12)

1. High Voltage—Type'K'

2. Temperature Coefficient (Ref. Fig 1 & 2)

CLASS I : N (CH) , S (SL)

CLASS II : P (Y5P), Z (Z5U), V (Z5V)

3. Rated Voltage (D.C.)

Code	Voltage	Code	Voltage
2K0	2000V	6K3	6300V
3K0	3000V	8K0	8000V
4K0	4000V	10K	10000V
5K0	5000V	15K	15000V
6K0	6000V		

4. Rated Capacitance

100PF ~ 47000PF in E-24 Series Coded by

Two Significant digits + No. of Zero

5. Tolerance On Rated Capacitance

J = ±5%, K = ±10%, M = ±20%, Z = +80 ~ -20 %

6. Lead Shape. (Ref. Fig. 3.)

Code	Type	
K	Bulk	Short Kink
S		Short Straight
L		Long Straight
A	Taping	Inside kink
B		Straight

7. Lead Spacing. (F)

Code	Dimension. (mm)		
	K	S	L
5	5.0 ± 0.8		
6	6.35 ± 0.8		
7	7.5 ± 0.8		
0	9.5 ± 0.8		

8. Lead Length. (L)

Code	Dimension (mm)		
	K	S	L
5	5.0 ± 0.8	5.0 ± 0.8	
6	6.0 ± 0.8	6.0 ± 0.8	
0	10.0 ± 0.8	10.0 ± 0.8	
1	---	---	25min

9. Lead Wire. (d)

Code	Dia (φ mm)	Rated Voltage (D.C.)
6	0.6 ± 0.05	2KV~ 8KV
8	0.8 ± 0.05	6KV~ 15KV

10. Package

Code	Package	Q'ty
B	Bulk	1000pcs
A	Ammo Pack	2000pcs
R	Tape Reel	2500pcs

11. Extra Diameter Code : D

12. Diameter in mm

Code	Dia (φ mm)
9	9
11.5	11.5

HIGH VOLTAGE CERAMIC CAPACITORS 2KV-15KV

RATED VOLTAGE (DC)	Temperature Characteristic / Capacitance (pF)					Size max
	N (CH)	S(SL)	P (Y5P)	Z (Z5U)	V (Z5V)	Dia (ø mm)
2KV	1 – 27	10 – 68	100 – 470	1000 – 1500	1000 – 1500	6.5
	30 – 39	80 – 100	560 – 1000	1800 – 2700	1800 – 2700	7.5
	47 – 68	120 – 150	1200 – 1500	3000 – 3900	3000 – 5000	8.5
	-	180 – 220	1800	4700 – 5000	5600 – 6800	9.5
	75 – 82	270 – 300	2200	5600 – 6800	10000	10.5
	-	330 – 390	3300	10000	-	11.5
	100 – 120	-	-	-	-	12.5
	-	470	3900 – 5000	-	15000 – 18000	14.5
	-	-	5600 – 6800	15000 – 18000	20000 – 22000	15.5
	-	560	-	-	-	16.5
	-	-	10000	20000 - 22000	-	17.5
3KV	1 – 18	10 – 56	100 – 470	1000	1000	6.5
	20 – 30	68 – 82	560 – 680	1200	1200 – 2000	7.5
	33	100	820 – 1000	1500 – 1800	2200 – 2700	8.5
	-	120 – 150	-	2000 – 2700	3000 – 5000	9.5
	36 – 47	180	1200 – 1500	3000 – 3900	5600 – 6800	10.5
	-	200	1800 – 2200	4700 – 5000	8200	11.5
	56 – 68	-	-	-	-	12.5
	-	220 – 300	2700 – 3300	5600	-	13.5
	82	-	-	6800	-	14.5
	-	330	3900 – 4700	8200 – 10000	10000	15.5
	100	390	-	-	-	16.5
	-	470 – 560	-	-	-	18.5

**For voltage higher than 3KV, please contact us for separate data sheet with the diameter of disc capacitors.

**All product specifications are subject to change without notice. Please confirm before you order.

Lead Shape (Fig. 3)

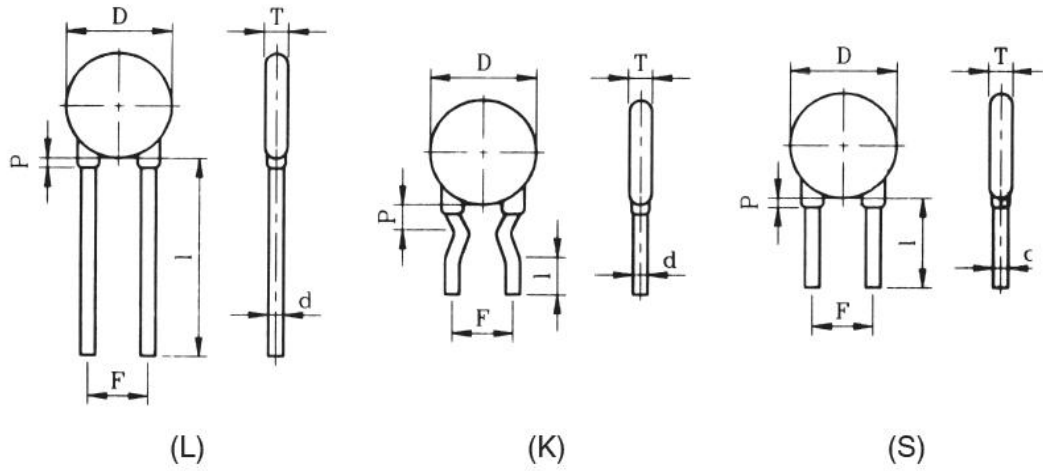

Taping Specification

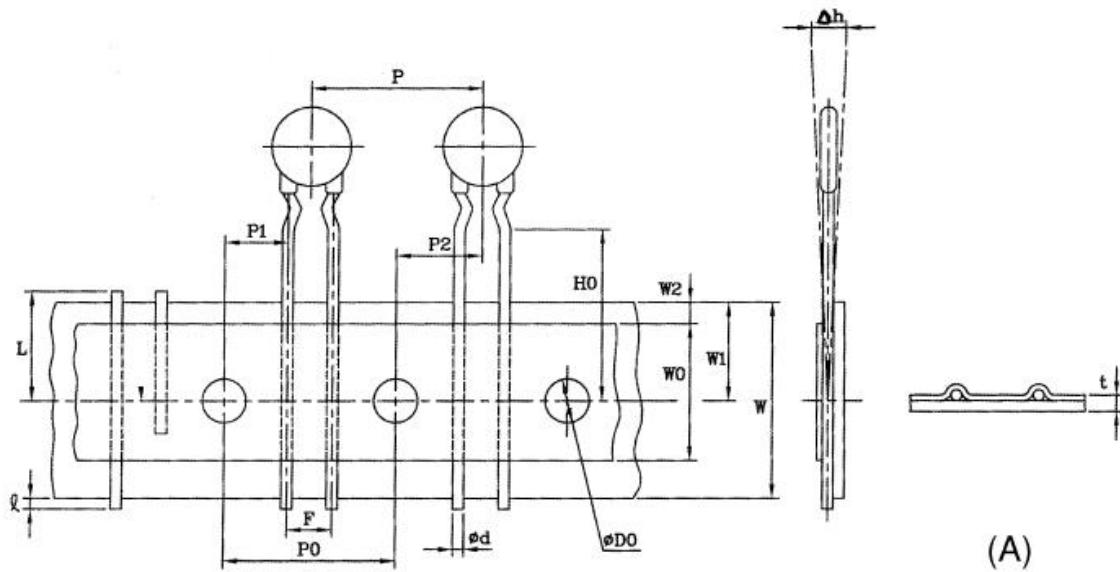

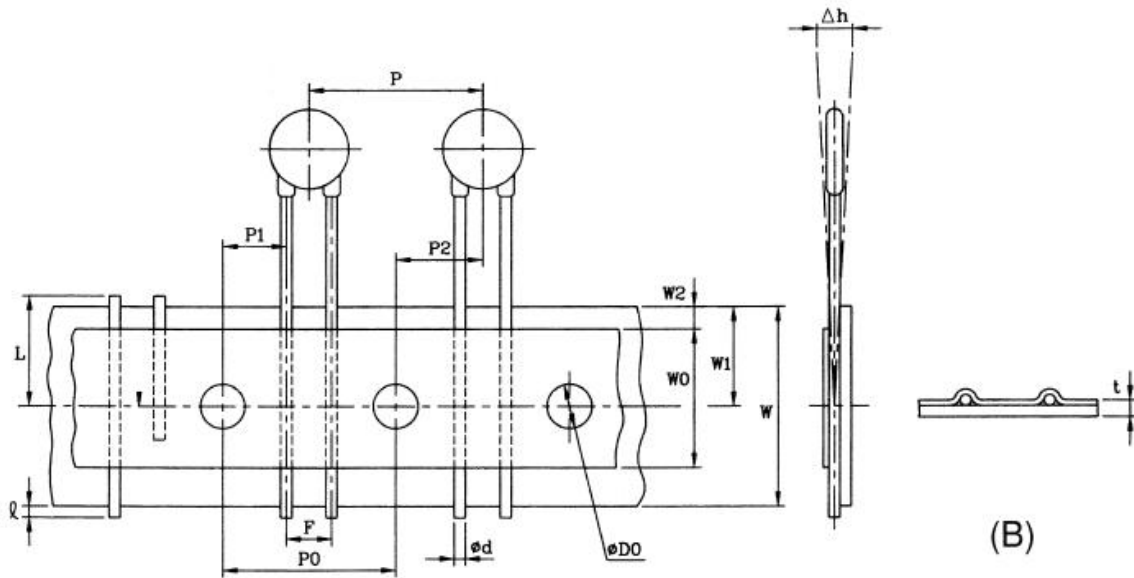

Symbol	P	P ₀	P ₁	P ₂	φd	F	Δh	W	W ₀	W ₁	W ₂	D ₀	t	L	H	H ₀
Dimension	12.7	12.7	3.85	6.35	0.6	5.08 6.35 7.62	0	18	12.5	9	3	4	0.7	11	20.0 23.0	16.0 18.0
Tolerance	±1.0	±0.3	±0.7	±1.0	±0.05	+0.8 -0.2	±2	±0.5	Min	+0.75 -0.5	Max	±0.3	±0.2	Max	+1.5 -1.0	±0.5