

REV	ECN	DATE	BY	APPR
-	ISSUED	5-10-83	-	-
A	-	8-9-83	SF	FDW
B	1070	1-14-85	JD	FDW
C	2705	11-3-89	TEZ	FDW
D	3456	10-31-91	PT	FDW
E	3503	12-20-91	TEZ	FDW
F	3574	3-12-92	PT	FDW
G	3693	7-24-92	TEZ	FDW
H	4591	3-6-95	CDJ	FDW
J	5377	8-27-97	TEZ	FDW
K	7060	4-4-02	CMB	TEZ
L	18722	6-4-10	BZ	TEZ
M	24444	10-1-15	JZ	TEZ



JFW INDUSTRIES, INC.

www.jfwindustries.com

PH: 317-887-1340

MATERIAL	BRASS	PROPRIETARY INFORMATION
FINISH	NICKEL	ALL SURFACES ARE TO BE FREE OF BURRS, PITS & SCRATCHES
MODEL	50AP-XXX	TOLERANCES .XX±.010 .XXX±.005 XX°±.5°
DESCRIPTION	ANALOG PROGRAMMABLE	DWG #
		092-250

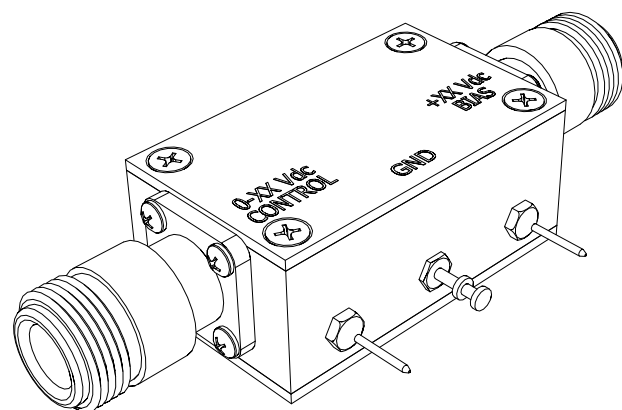
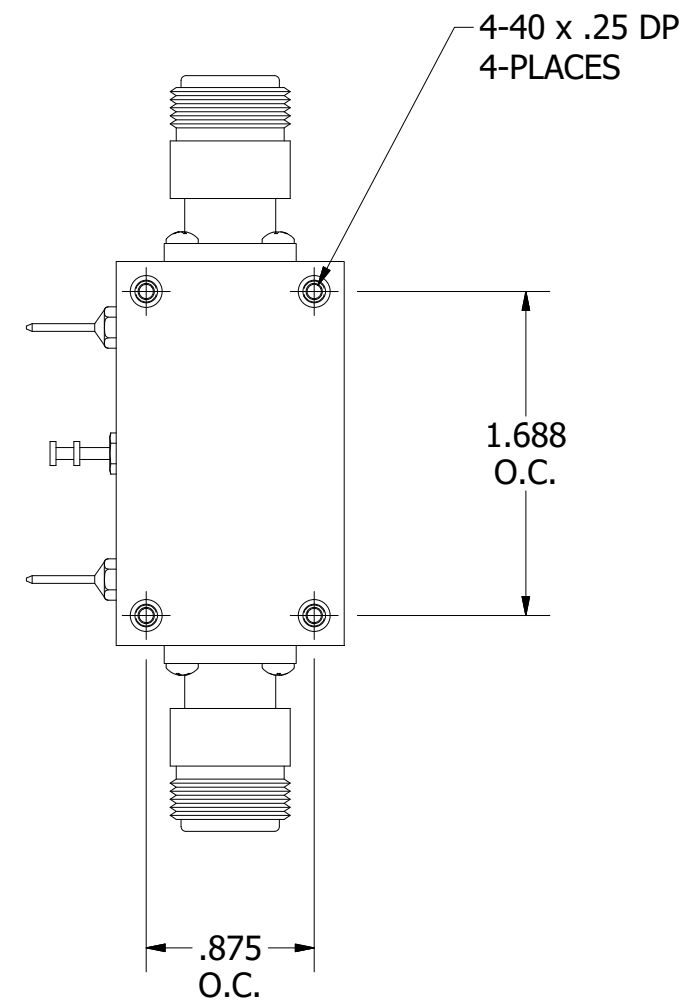
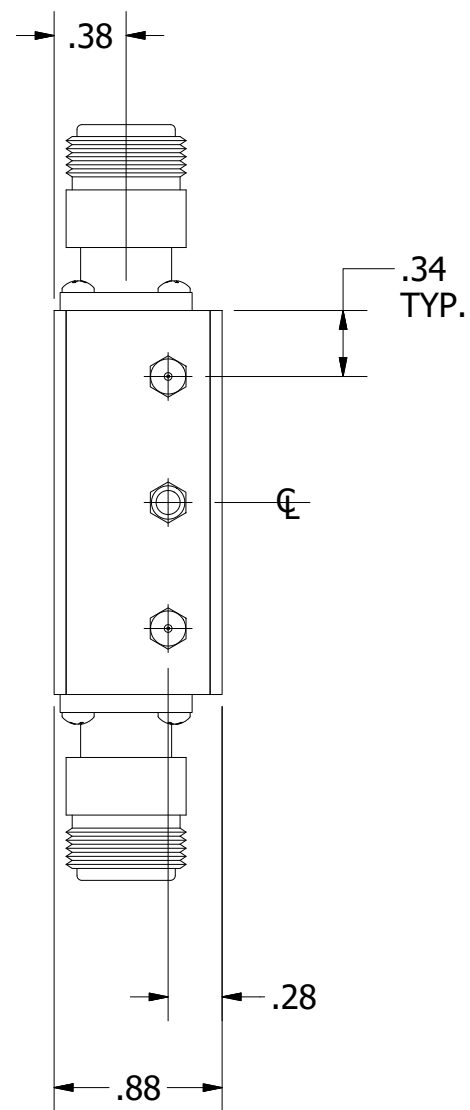
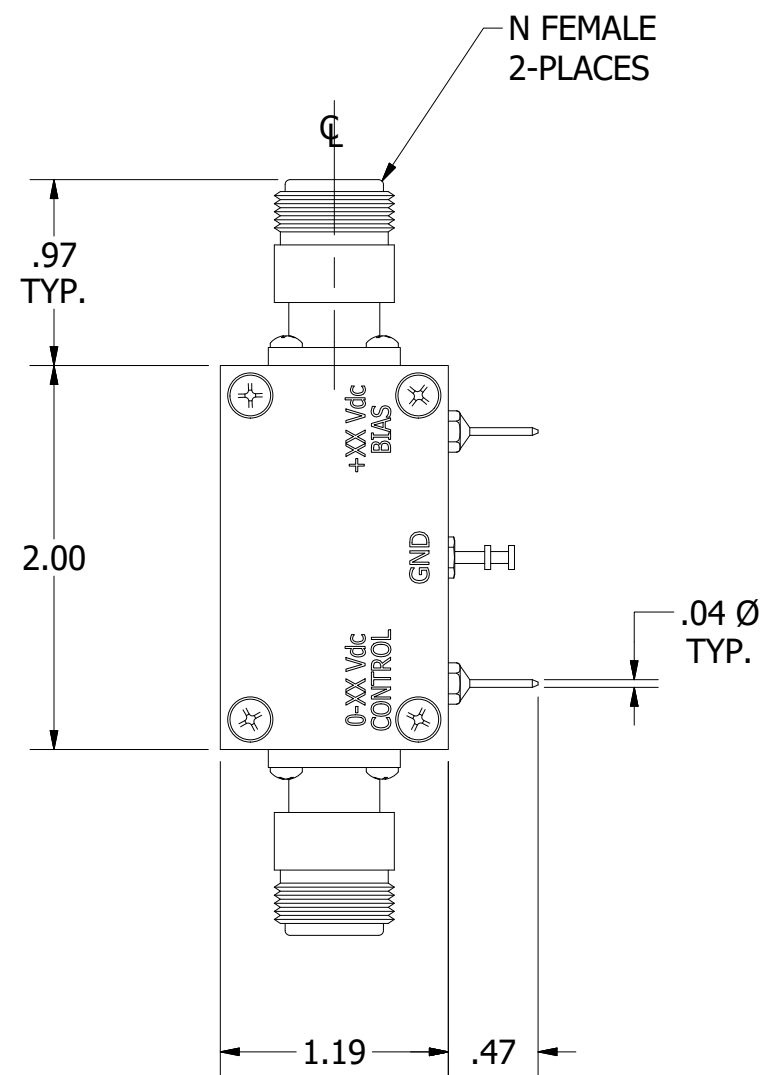

REV	ECN	DATE	BY	APPR
-	ISSUED	9-6-06	BZ	TEZ
A	28938	8-10-18	TEZ	TEZ



JFW INDUSTRIES, INC.

www.jfwindustries.com

PH: 317-887-1340

MATERIAL	BRASS	PROPRIETARY INFORMATION
FINISH	NICKEL	ALL SURFACES ARE TO BE FREE OF BURRS, PITS & SCRATCHES
MODEL	50AP-XXX	TOLERANCES
DESCRIPTION	ANALOG PROGRAMMABLE	.XX±.010 .XXX±.005 XX°±.5°
		DWG #
		092-5194