

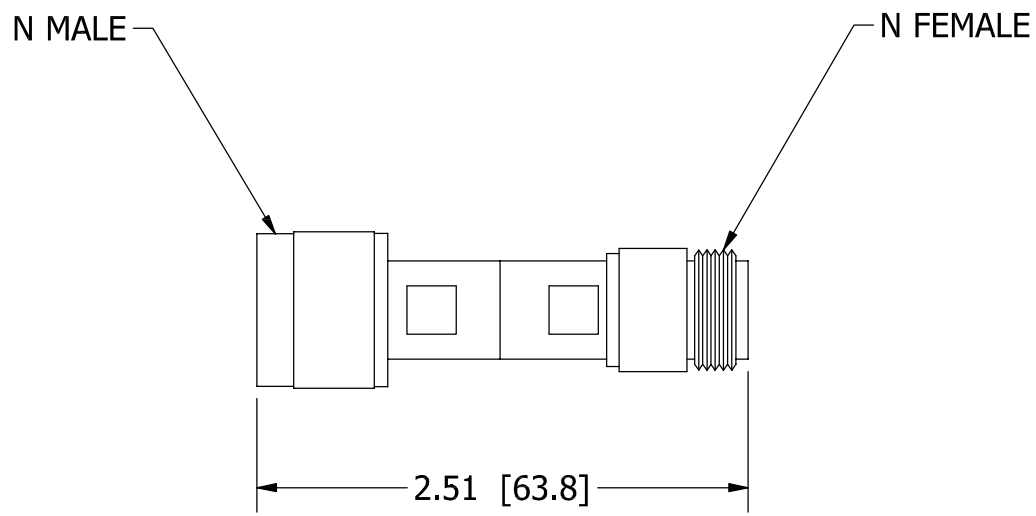

REV	ECN	DATE	BY	APPR
-	ISSUED	---	---	---
A	1911	2-2-88	PT	FDW
B	5828	10-6-98	CDJ	TEZ
C	5942	2-25-99	TEZ	TEZ
D	7094	4-23-02	CMB	TEZ
E	24444	9-4-19	GM	JZ

		<h1>JFW INDUSTRIES, INC.</h1>	
		www.jfwindustries.com PH: 317-887-1340	
MATERIAL			PROPRIETARY INFORMATION
FINISH			ALL SURFACES ARE TO BE FREE OF BURRS, PITS & SCRATCHES
MODEL		SCALE	TOLERANCES
DESCRIPTION		FULL	.XX±.010 .XXX±.005 XX°±.5°
BNC FEMALE / MALE			DWG #
BNC FEMALE / MALE			092-004



REV	ECN	DATE	BY	APPR			
-	ISSUED	11-6-82	MR	FDW	 JFW INDUSTRIES, INC. www.jfwindustries.com PH: 317-887-1340		
A	2246	11-30-88	PT	FDW			
B	2955	6-5-90	TEZ	FDW			
C	2992	7-23-90	TEZ	FDW			
D	3981	6-10-93	TEZ	FDW			
E	4194	3-30-94	PT	TEZ	MATERIAL	BRASS	PROPRIETARY INFORMATION
F	4284	7-8-94	TEZ	FDW	FINISH	NICKEL	ALL SURFACES ARE TO BE FREE OF BURRS, PITS & SCRATCHES
G	5337	8-1-97	CDJ	TEZ	MODEL		TOLERANCES
H	5850	10-29-98	PT	TEZ		SCALE	FULL
J	7393	3-3-03	TEZ	TEZ	DESCRIPTION		.XX±.010 .XXX±.005 XX°±.5°
K	7893	6-21-04	BZ	TEZ			DWG #
L	7957	8-12-04	TEZ	TEZ			
M	14935	11-7-07	TRS	TEZ			
N	25348	5-19-15	BZ	TEZ			
					OUTLINE DRAWING		092-164

SMA FEMALE

SMA MALE

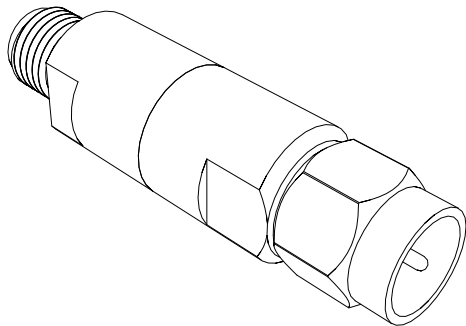
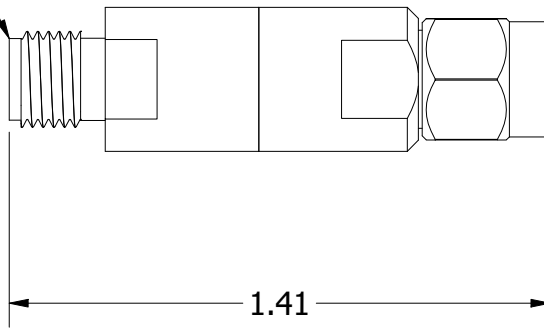

REV	ECN	DATE	BY	APPR
-	ISSUED	10-7-82	---	---
A	1104	3-6-85	PT	FDW
B	2389	3-5-89	PT	FDW
C	4162	2-25-94	PT	FDW
D	4700	7-10-95	PT	FDW
E	4908	2-29-96	CDJ	FDW
F	4944	4-3-96	CDJ	FDW
G	24444	9-9-19	GM	JZ



JFW INDUSTRIES, INC.

www.jfwindustries.com

PH: 317-887-1340

MATERIAL	PROPRIETARY INFORMATION
FINISH	ALL SURFACES ARE TO BE FREE OF BURRS, PITS & SCRATCHES
MODEL	SCALE x2
DESCRIPTION	TOLERANCES .XX±.010 .XXX±.005 XX°±.5° DWG #
SMA FEMALE / SMA MALE	
092-199	