

CONNECTOR	DIM. A	DIM. B
SMA MALE	.51	.51
SMA FEMALE	.47	.47
BNC MALE	.78	.75
BNC FEMALE	.61	.61
TNC MALE	.75	.75
TNC FEMALE	.55	.55
N MALE	.91	N/A
N FEMALE	.68	.68
7/16 MALE	1.26	N/A
7/16 FEMALE	1.17	N/A
4.1/9.5 MALE	.91	N/A
4.1/9.5 FEMALE	.91	N/A
4.3/10 MALE	1.02	N/A
4.3/10 FEMALE	.96	N/A
F MALE	.47	.47
F FEMALE	.56	.56

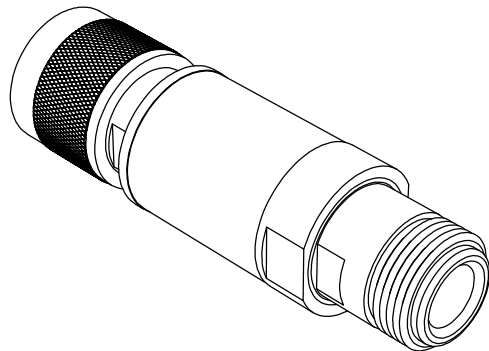

REV	ECN	DATE	BY	APPR
-	ISSUED	9-1-99	MH	FDW
A	6144	11-15-99	TEZ	FDW
B	6941	12-12-01	MAH	TEZ
C	23948	3-27-14	JZ	TEZ
D	26370	3-7-16	JZ	TEZ
E	26706	6-9-16	JZ	CLK
F	26796	6-7-16	JZ	TEZ
G	26869	7-26-16	TB	TEZ
H	27494	1-23-17	JZ	TRS

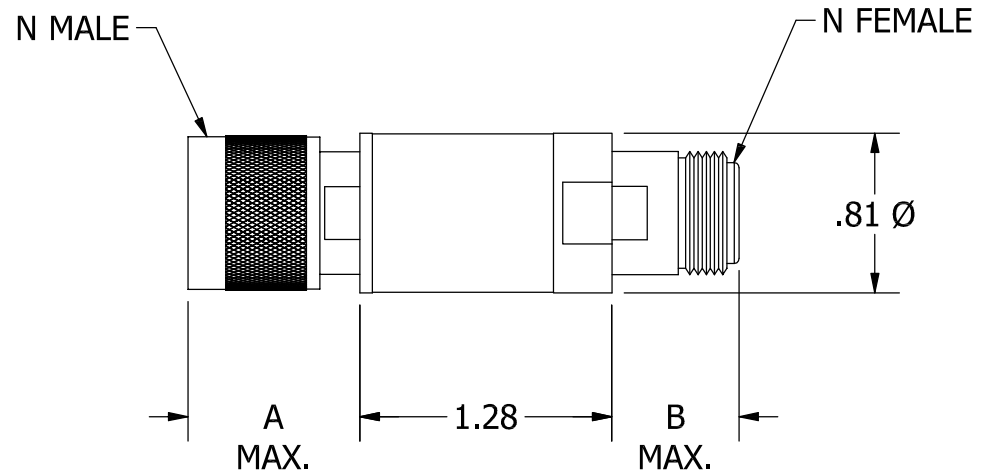

**JFW INDUSTRIES, INC.**

[www.jfwindustries.com](http://www.jfwindustries.com)

PH: 317-887-1340

MATERIAL	PROPRIETARY INFORMATION
FINISH	ALL SURFACES ARE TO BE FREE OF BURRS, PITS & SCRATCHES
MODEL	TOLERANCES .XX±.010 .XXX±.005 XX°±.5°
DESCRIPTION	DWG #
VARIOUS	092-3134

SCALE  
FULL

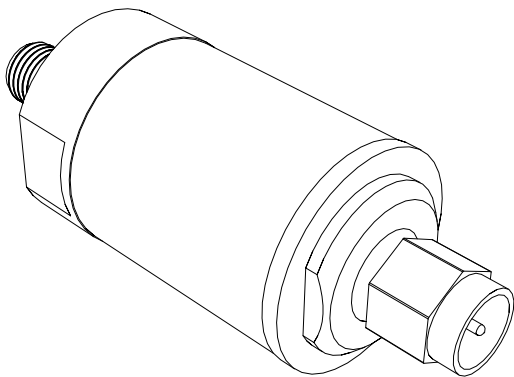
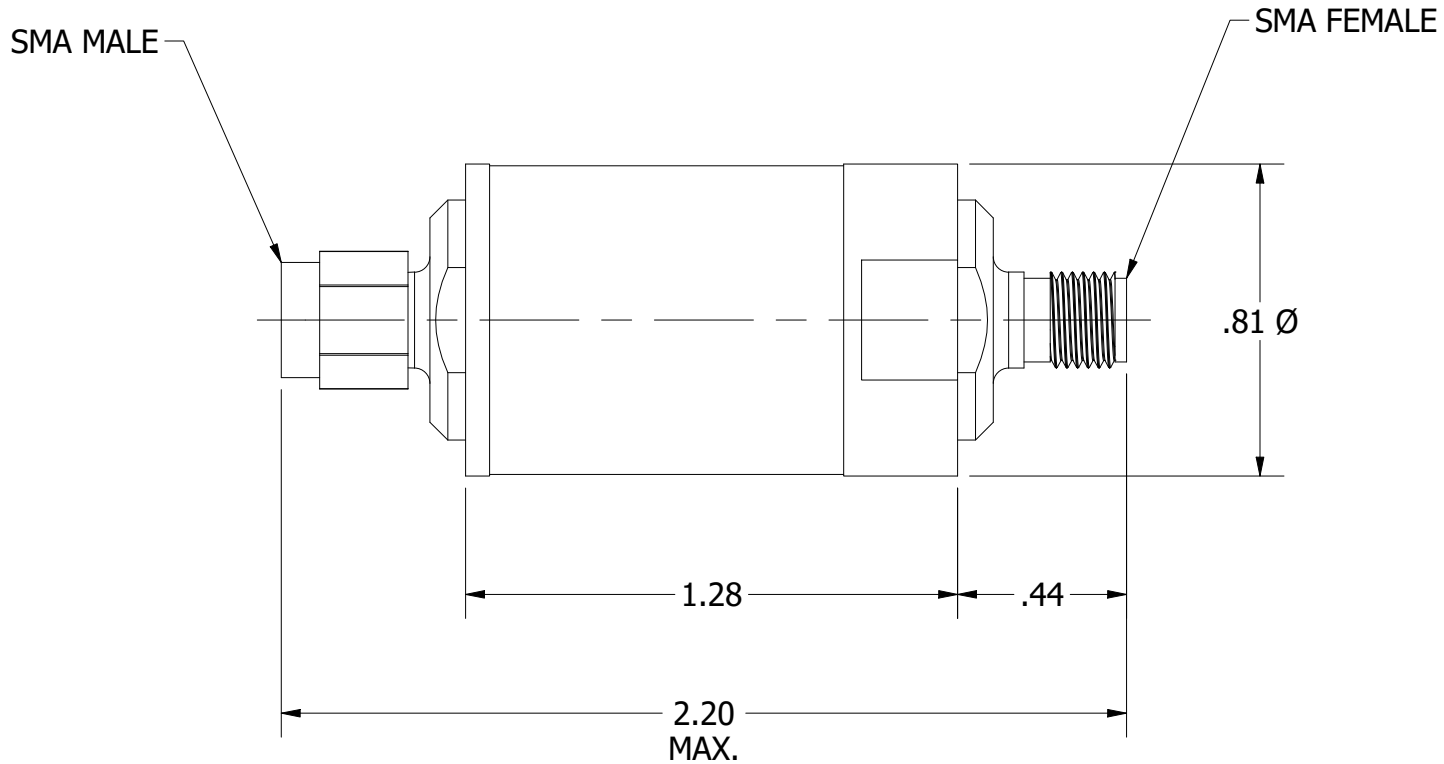

REV	ECN	DATE	BY	APPR
-	ISSUED	8-13-03	TEZ	SL
A	11251	5-27-05	TEZ	SL
B	18881	7-15-10	JZ	TEZ
C	24444	9-12-19	GM	JZ

		<h1>JFW INDUSTRIES, INC.</h1>	
		<a href="http://www.jfwindustries.com">www.jfwindustries.com</a> PH: 317-887-1340	
MATERIAL		BRASS	
FINISH		NICKEL	
MODEL		SCALE FULL	
DESCRIPTION		TOLERANCES .XX±.010 .XXX±.005 XX°±.5°	
SMA MALE / SMA FEMALE		DWG # 092-4276	
		PROPRIETARY INFORMATION	
		ALL SURFACES ARE TO BE FREE OF BURRS, PITS & SCRATCHES	