

REV	ECN	DATE	BY	APPR
-	ISSUED	8-7-83	-	-
A	2083	6-20-88	TEZ	FDW
B	6914	11-27-01	MAH	TEZ
C	7395	3-3-03	TEZ	TEZ
D	7558	9-22-03	TEZ	TEZ
E	10136	11-8-04	LT	TEZ
F	24444	9-12-19	GM	JZ
G	30613	9-24-20	GM	JZ



JFW INDUSTRIES, INC.

www.jfwindustries.com

PH: 317-887-1340

MATERIAL	BRASS	PROPRIETARY INFORMATION
FINISH	NICKEL	ALL SURFACES ARE TO BE FREE OF BURRS, PITS & SCRATCHES
MODEL	SCALE x2	TOLERANCES .XX±.010 .XXX±.005 XX°±.5°
DESCRIPTION	BNC MALE / BNC FEMALE	DWG # 092-429

SMA FEMALE

SMA MALE

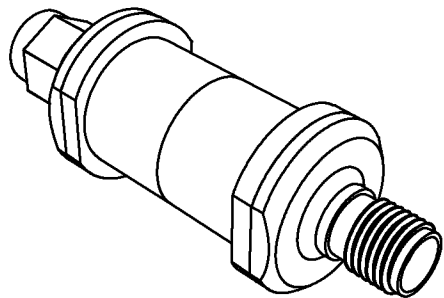
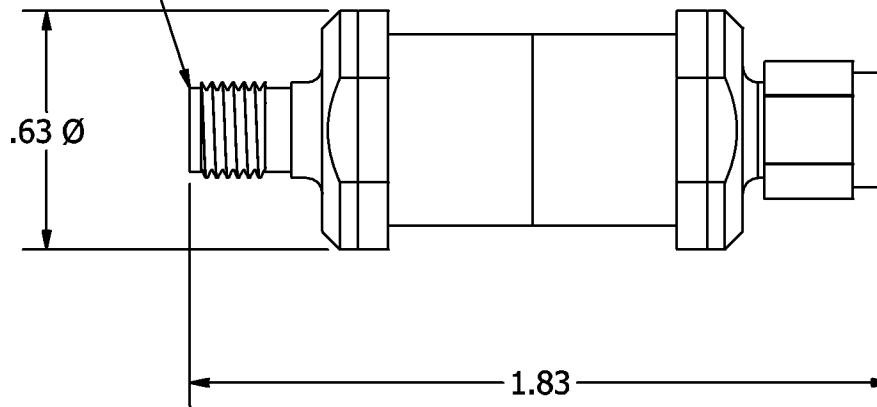

REV	ECN	DATE	BY	APPR
-	ISSUED	1-18-13	TEZ	TEZ
A	24444	9-5-19	GM	JZ
B	30613	8-21-20	JZ	JZ



JFW INDUSTRIES, INC.

www.jfwindustries.com

PH: 317-887-1340

MATERIAL	PROPRIETARY INFORMATION
FINISH	ALL SURFACES ARE TO BE FREE OF BURRS, PITS & SCRATCHES
MODEL	SCALE x2
DESCRIPTION	TOLERANCES .XX±.010 .XXX±.005 XX°±.5°
SMA MALE / FEMALE	DWG # 092-1324-01

N FEMALE

N MALE

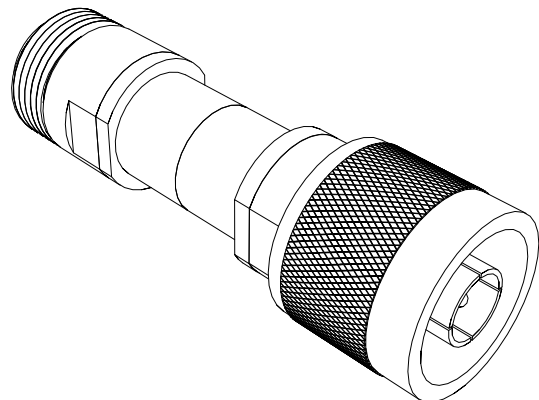
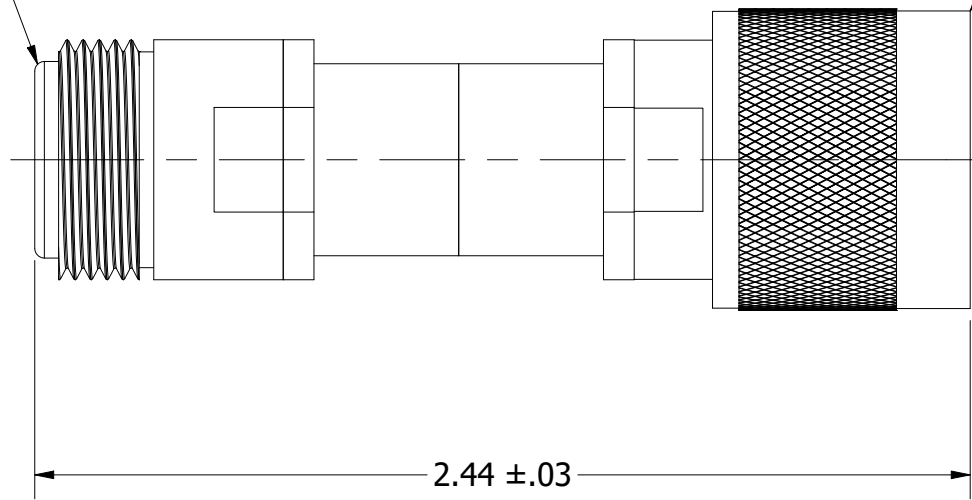

REV	ECN	DATE	BY	APPR
-	ISSUED	3-3-03	TEZ	TEZ
A	7558	9-22-03	TEZ	TEZ
B	14315	6-26-07	TEZ	TEZ
C	24444	9-12-19	GM	JZ



JFW INDUSTRIES, INC.

www.jfwindustries.com

PH: 317-887-1340

MATERIAL	PROPRIETARY INFORMATION
FINISH	ALL SURFACES ARE TO BE FREE OF BURRS, PITS & SCRATCHES
MODEL	TOLERANCES
DESCRIPTION	.XX±.010 .XXX±.005 XX°±.5°
N FEMALE / N MALE	
SCALE	x2
DWG #	092-4159