

UNIT IS UNI-DIRECTIONAL

REV	ECN	DATE	BY	APPR
-	ISSUED	1-4-12	JZ	TEZ
A	22005	10-15-12	BZ	TEZ
B	24444	9-20-19	GM	TEZ

 JFW INDUSTRIES, INC. www.jfwindustries.com PH: 317-887-1340		PROPRIETARY INFORMATION
		ALL SURFACES ARE TO BE FREE OF BURRS, PITS & SCRATCHES
MATERIAL	ALUMINUM ALLOY	TOLERANCES
FINISH	BLACK ANODIZE	.XX±.010 .XXX±.005 XX*±.5"
MODEL	50HF-XXX-100/6	SCALE FULL
DESCRIPTION	100 WATT FIXED ATTEN.	DWG # 092-7189

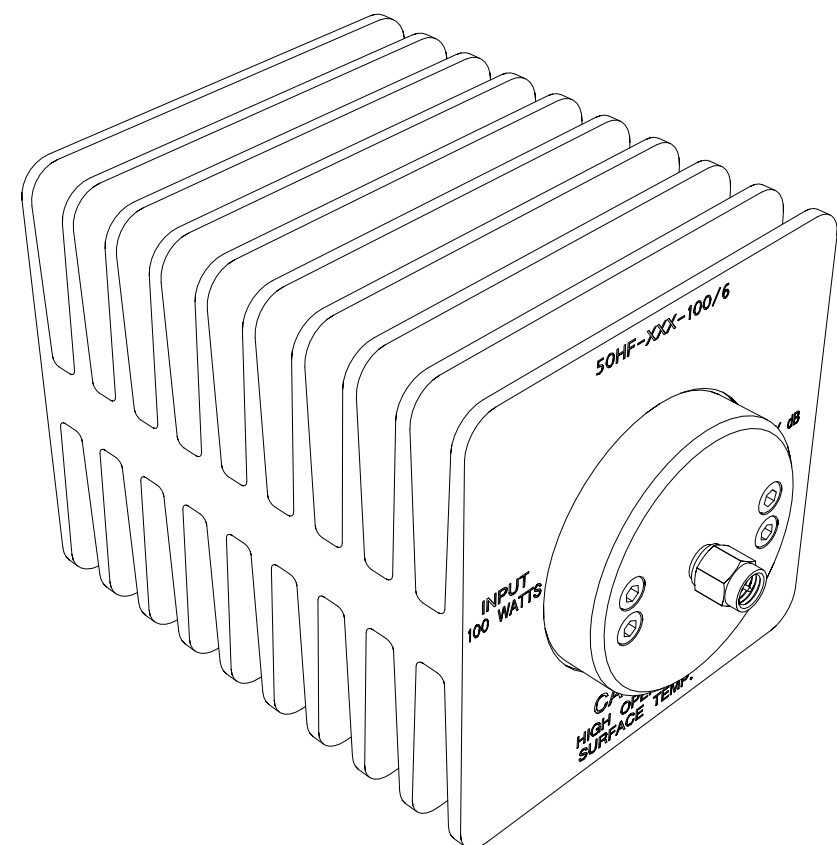
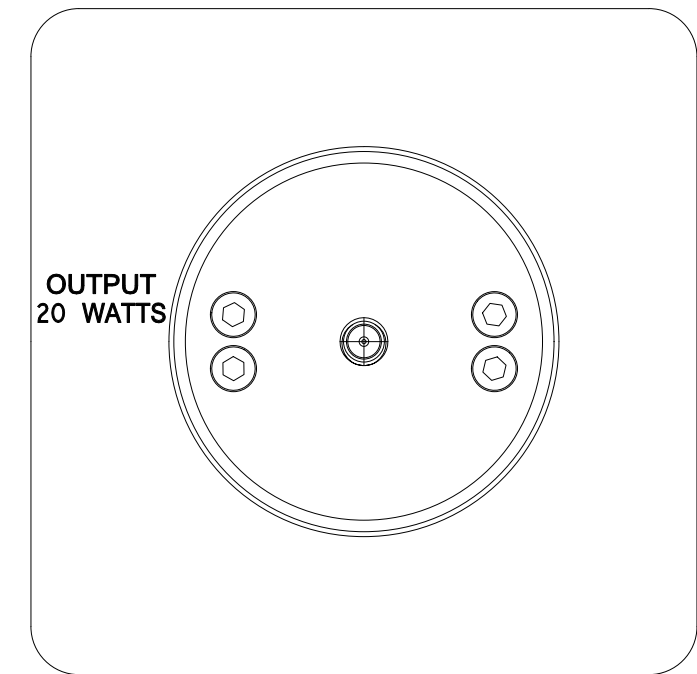
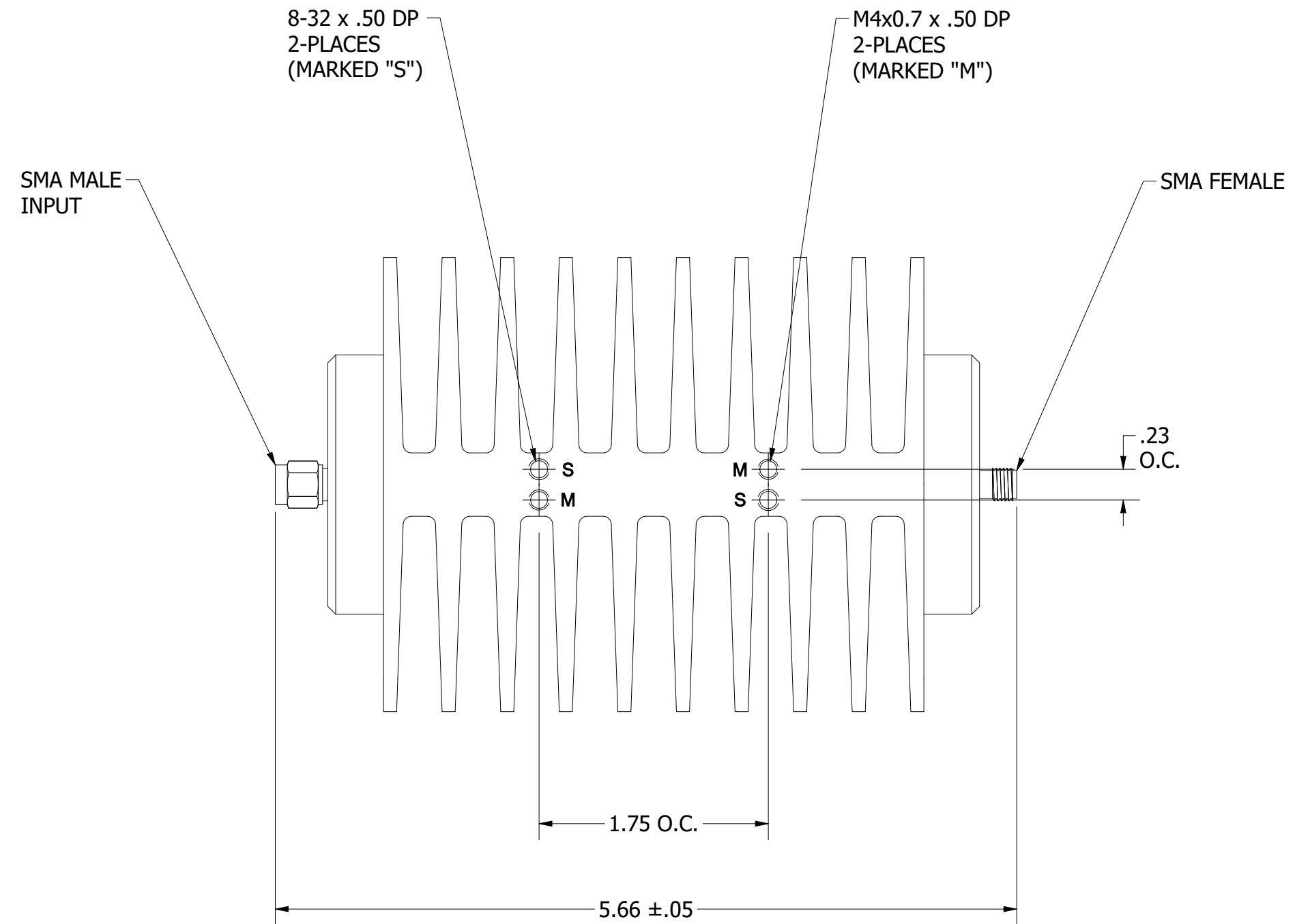
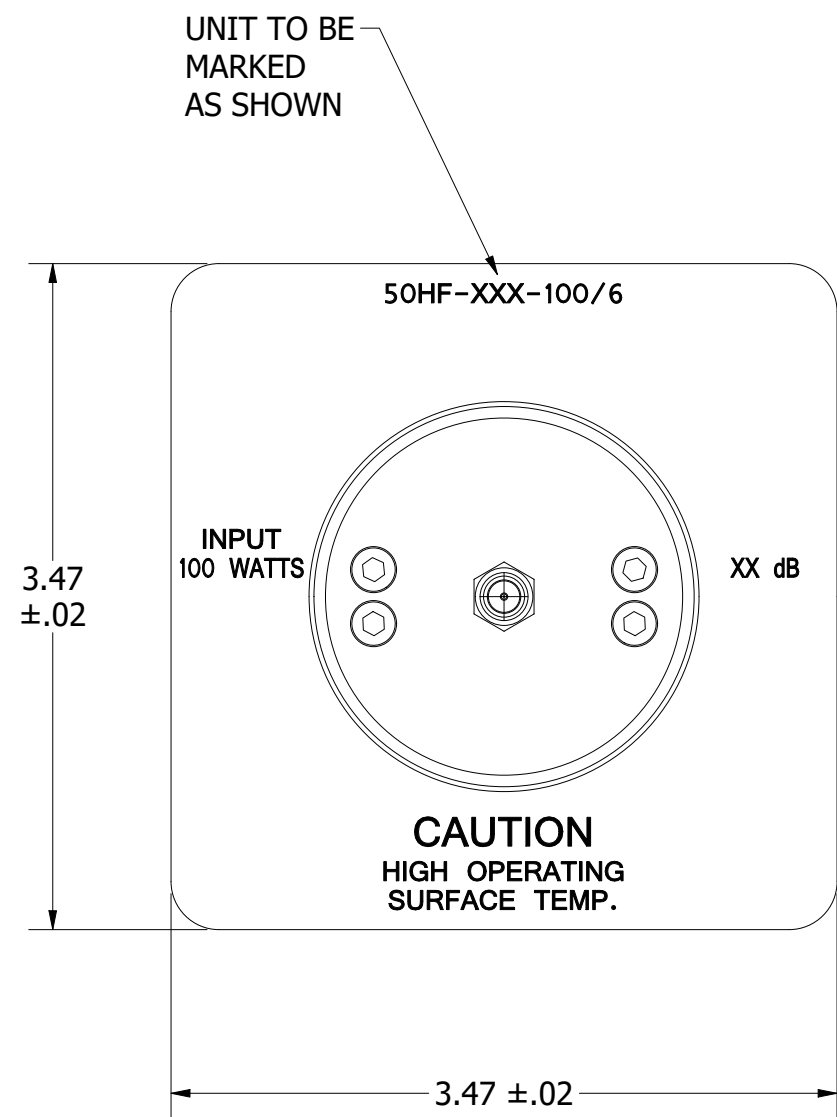

UNIT IS UNI-DIRECTIONAL

REV	ECN	DATE	BY	APPR
-	ISSUED	6-19-12	BZ	TEZ
A	22013	10-19-12	BZ	TEZ
B	24444	9-23-19	GM	TEZ

		JFW INDUSTRIES, INC.	
		www.jfwindustries.com PH: 317-887-1340	
MATERIAL		ALUMINUM ALLOY	PROPRIETARY INFORMATION
FINISH		BLACK ANODIZE	ALL SURFACES ARE TO BE FREE OF BURRS, PITS & SCRATCHES
MODEL		50HF-XXX-100/6	TOLERANCES
DESCRIPTION		100 WATT FIXED ATTEN.	.XX±.010 .XXX±.005 XX*±.5"
		SCALE FULL	DWG # 092-7388