

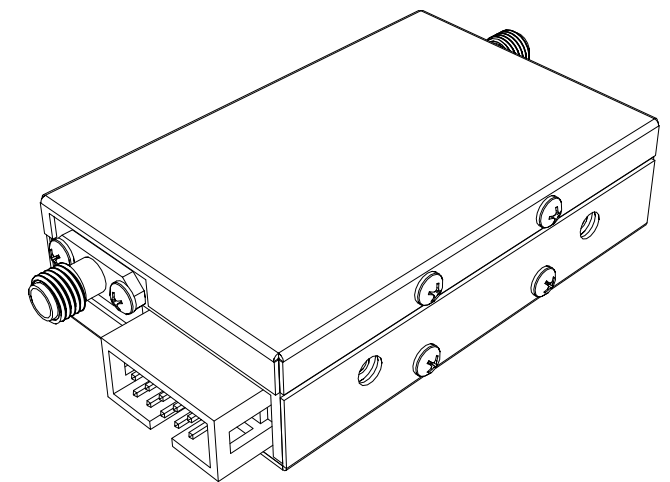

DETAIL A
3M #D2510-6002-AR
OR EQUIVALENT



PIN	50P-1767 FUNCTION	50P-1768/1963 FUNCTION	50P-1769/2077 FUNCTION
1	10dB TTL CONTROL	5dB TTL CONTROL	.1dB TTL CONTROL
2	20dB TTL CONTROL	10dB TTL CONTROL	.2dB TTL CONTROL
3	40dB TTL CONTROL	20dB TTL CONTROL	.4dB TTL CONTROL
4	NO CONNECTION	20dB TTL CONTROL	.8dB TTL CONTROL
5	NO CONNECTION	NO CONNECTION	NO CONNECTION
6	NO CONNECTION	NO CONNECTION	NO CONNECTION
7	NO CONNECTION	NO CONNECTION	NO CONNECTION
8	NO CONNECTION	NO CONNECTION	NO CONNECTION
9	+XX Vdc	+XX Vdc	+XX Vdc
10	GROUND	GROUND	GROUND

REV	ECN	DATE	BY	APPR	 JFW INDUSTRIES, INC. www.jfwindustries.com PH: 317-887-1340	
-	ISSUED	5-07-07	TRS	TEZ	MATERIAL BRASS	
A	24444	9-17-15	JZ	TEZ	FINISH NICKEL	
B	25851	10-29-15	JZ	TEZ	MODEL 50P-XXXX	
C	28530	2-23-18	JZ	TEZ	SCALE FULL	
D	29124	6-18-19	ICC	JZ	DESCRIPTION PROGRAMMABLE ATTENUATOR	
					PROPRIETARY INFORMATION ALL SURFACES ARE TO BE FREE OF BURRS, PITS & SCRATCHES TOLERANCES .XX±.010 .XXX±.005 XX*±.5° DWG # 092-5411	