

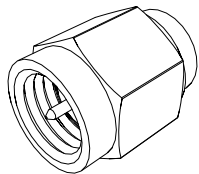

SMA MALE

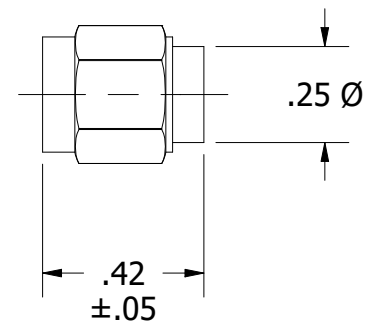
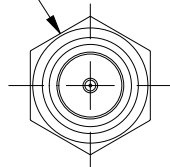

REV	ECN	DATE	BY	APPR
-	ISSUED	2-3-12	JZ	TEZ
A	24444	9-23-19	GM	TEZ

		<h1>JFW INDUSTRIES, INC.</h1>	
		<p>www.jfwindustries.com PH: 317-887-1340</p>	
MATERIAL	STAINLESS STEEL		PROPRIETARY INFORMATION
FINISH	PASSIVATED		ALL SURFACES ARE TO BE FREE OF BURRS, PITS & SCRATCHES
MODEL	SCALE	x2	TOLERANCES .XX±.010 .XXX±.005 XX°±.5°
DESCRIPTION	TERMINATION		DWG # 092-7213

SMA MALE

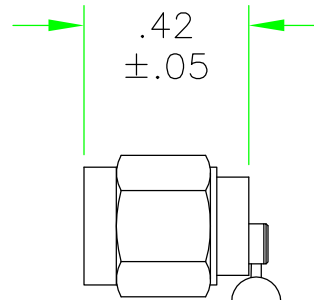
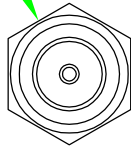

.13 ϕ THRU

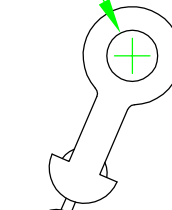

#6 BALL CHAIN
3.5 LG



JFW INDUSTRIES, INC.

www.jfwindustries.com

PH: 317-887-1340

REV	ECN	DATE	BY	APPR
-	ISSUED	2-3-12	JZ	TEZ

MATERIAL	STAINLESS STEEL		PROPRIETARY INFORMATION ALL SURFACES ARE TO BE FREE OF BURRS, PITS, & SCRATCHES
FINISH	PASSIVATED		
MODEL	SCALE	X2	TOLERANCES .XX±.010 .XXX±.005 XX'±.5'
DESCRIPTION	TERMINATION		DWG # 092-7215

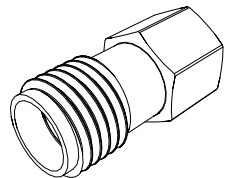
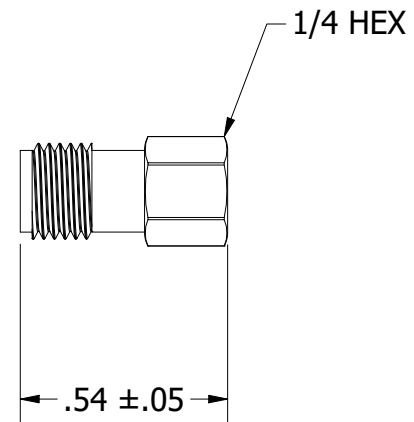
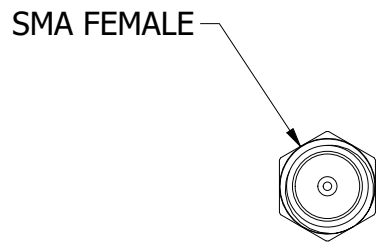

REV	ECN	DATE	BY	APPR
-	ISSUED	2-3-12	JZ	TEZ
A	24444	9-23-19	GM	TEZ

		JFW INDUSTRIES, INC. www.jfwindustries.com PH: 317-887-1340	
		MATERIAL	STAINLESS STEEL
FINISH	PASSIVATED	ALL SURFACES ARE TO BE FREE OF BURRS, PITS & SCRATCHES	
MODEL		SCALE	x2
DESCRIPTION	TERMINATION	TOLERANCES .XX±.010 .XXX±.005 XX°±.5° DWG #	
		092-7214	