

REV	ECN	DATE	BY	APPR
-	ISSUED	4-23-03	BZ	TEZ
A	13921	3-2-07	TEZ	CLK
B	24444	11-13-15	BZ	TEZ
C	24444	9-28-16	TB	XXX



JFW INDUSTRIES, INC.

www.jfwindustries.com

PH: 317-887-1340

MATERIAL	BRASS	PROPRIETARY INFORMATION
FINISH	NICKEL	ALL SURFACES ARE TO BE FREE OF BURRS, PITS & SCRATCHES
MODEL	SCALE 2X	TOLERANCES .XX±.010 .XXX±.005 XX°±.5°
DESCRIPTION	N MALE TERMINATION	DWG # 092-4208

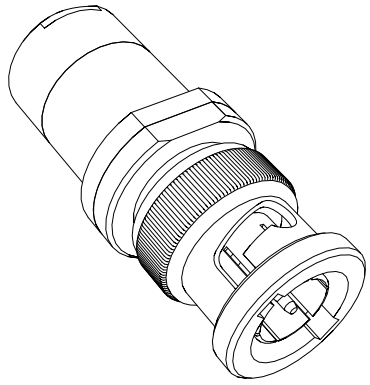
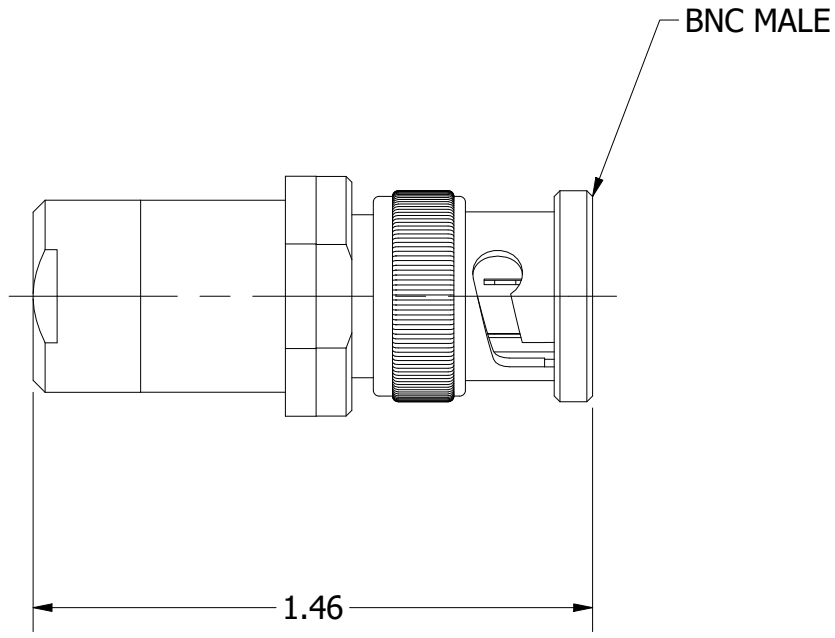

REV	ECN	DATE	BY	APPR
-	ISSUED	1-12-09	TEZ	TEZ
A	24444	9-17-19	GM	TEZ

		<h1>JFW INDUSTRIES, INC.</h1>	
		<p>www.jfwindustries.com PH: 317-887-1340</p>	
MATERIAL		BRASS	
FINISH		NICKEL	
MODEL		50T-XXX	SCALE x2
DESCRIPTION		TERMINATION	
		<p>PROPRIETARY INFORMATION</p> <p>ALL SURFACES ARE TO BE FREE OF BURRS, PITS & SCRATCHES</p> <p>TOLERANCES .XX±.010 .XXX±.005 XX°±.5°</p> <p>DWG #</p> <p>092-6043</p>	

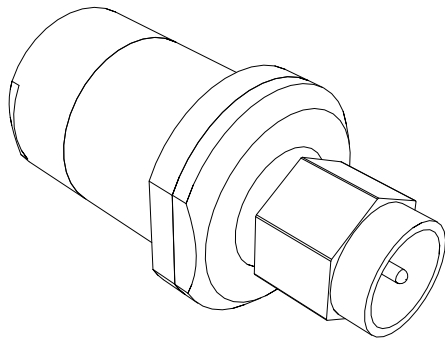
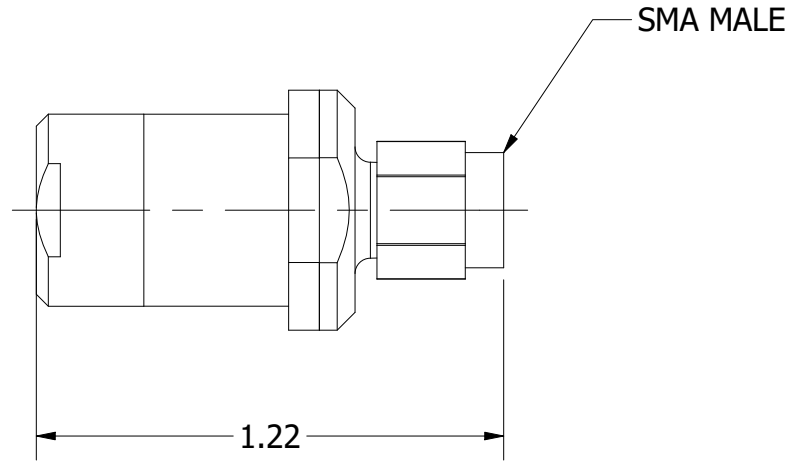

REV	ECN	DATE	BY	APPR
-	ISSUED	8-4-03	BZ	TEZ
A	24444	9-12-19	GM	TEZ



JFW INDUSTRIES, INC.

www.jfwindustries.com

PH: 317-887-1340

MATERIAL	PROPRIETARY INFORMATION	
FINISH	ALL SURFACES ARE TO BE FREE OF BURRS, PITS & SCRATCHES	
MODEL	50T-XXX	SCALE x2
DESCRIPTION	TERMINATION	TOLERANCES .XX±.010 .XXX±.005 XX°±.5° DWG # 092-4269