

CONNECTOR	DIM. A ±.03
SMA MALE	.73
SMA FEMALE	.69
BNC MALE	.97
BNC FEMALE	.77
TNC MALE	.97
TNC FEMALE	.77
N MALE	1.12
N FEMALE	.89
4.1/9.5 MALE	1.12
4.1/9.5 FEMALE	1.12
4.3/10 MALE	1.23
4.3/10 FEMALE	1.19

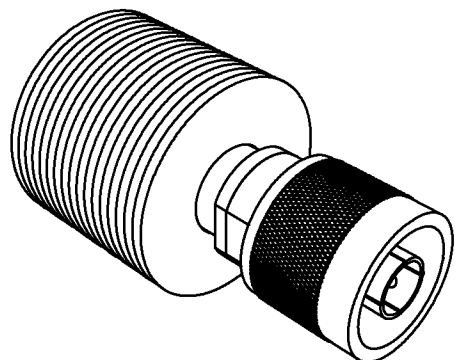

REV	ECN	DATE	BY	APPR
-	ISSUED	7-27-05	TEZ	SL
A	26593	4-29-16	TEZ	TRS
B	266684	5-26-16	TEZ	TEZ
C	24444	9-13-19	GM	JZ



**JFW INDUSTRIES, INC.**

[www.jfwindustries.com](http://www.jfwindustries.com)

PH: 317-887-1340

MATERIAL	ALUMINUM ALLOY	PROPRIETARY INFORMATION
FINISH	BLACK ANODIZE	ALL SURFACES ARE TO BE FREE OF BURRS, PITS & SCRATCHES
MODEL	50T-XXX-XX	SCALE FULL
DESCRIPTION	10 WATT TERMINATION	TOLERANCES .XX±.010 .XXX±.005 XX°±.5° DWG #
		092-4885

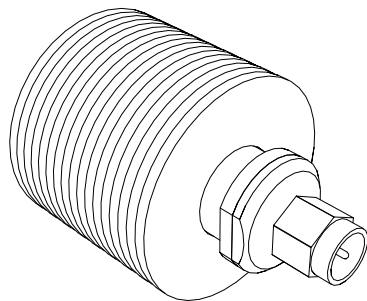
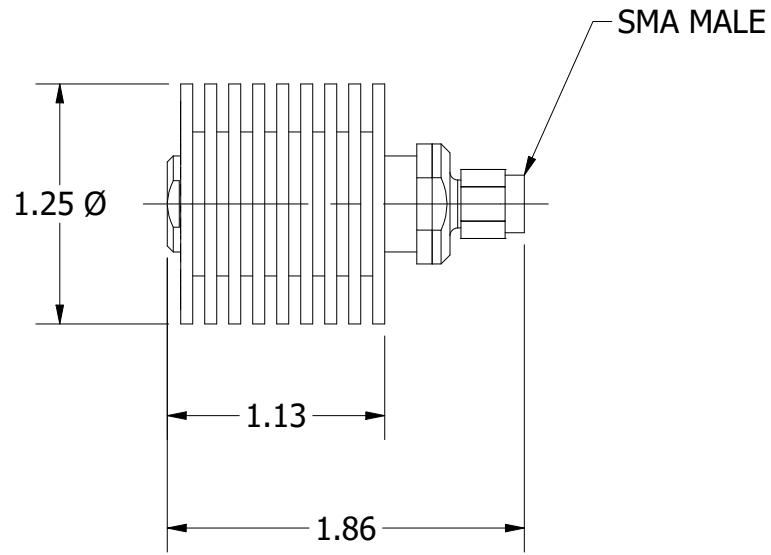

REV	ECN	DATE	BY	APPR
-	ISSUED	11-25-15	TEZ	TEZ
A	24444	10-23-19	GM	TEZ



**JFW INDUSTRIES, INC.**

[www.jfwindustries.com](http://www.jfwindustries.com)

PH: 317-887-1340

MATERIAL	PROPRIETARY INFORMATION	
FINISH	ALL SURFACES ARE TO BE FREE OF BURRS, PITS & SCRATCHES	
MODEL	50T-XXX-XX	SCALE FULL
DESCRIPTION	10 WATT TERMINATION	TOLERANCES .XX±.010 .XXX±.005 XX°±.5° DWG # 092-8491

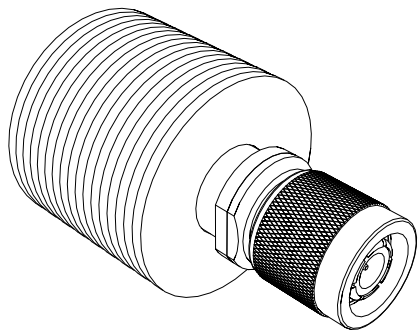
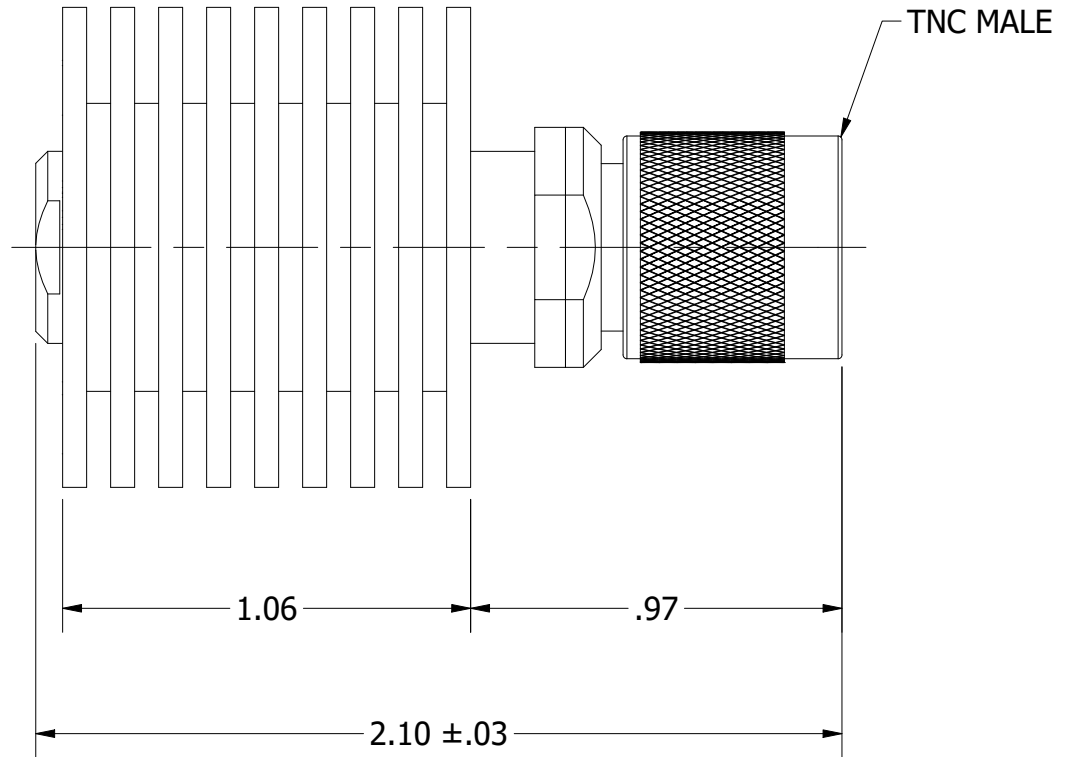
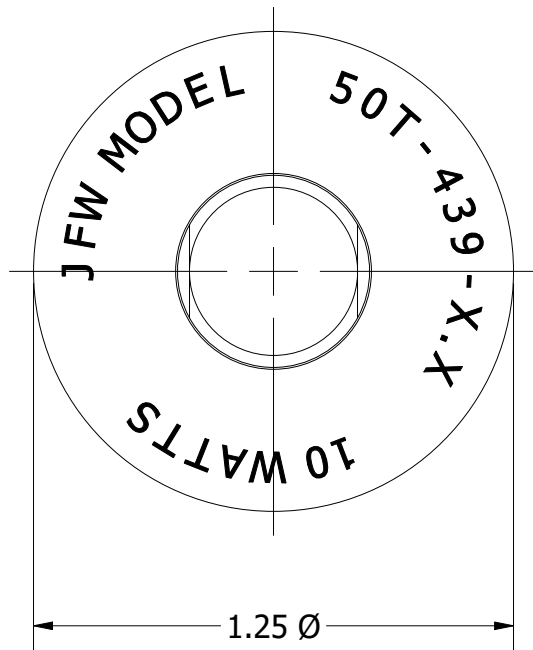

REV	ECN	DATE	BY	APPR
-	ISSUED	12-17-09	SMR	TEZ
A	24444	9-18-19	GM	TEZ



**JFW INDUSTRIES, INC.**

[www.jfwindustries.com](http://www.jfwindustries.com)

PH: 317-887-1340

MATERIAL	PROPRIETARY INFORMATION	
FINISH	ALL SURFACES ARE TO BE FREE OF BURRS, PITS & SCRATCHES	
MODEL	50T-439-XX	SCALE 2X
DESCRIPTION	10 WATT TERMINATION	TOLERANCES .XX±.010 .XXX±.005 XX°±.5° DWG # 092-6409