

REV	ECN	DATE	BY	APPR
-	ISSUED	3-16-09	TEZ	SMR
A	24444	10-21-19	GM	TEZ



JFW INDUSTRIES, INC.

www.jfwindustries.com

PH: 317-887-1340

MATERIAL	ALUMINUM ALLOY	PROPRIETARY INFORMATION
FINISH	CHEMFILM TCP / HEATSINK: BLACK ANODIZE	ALL SURFACES ARE TO BE FREE OF BURRS, PITS & SCRATCHES
MODEL	50T-XXX	TOLERANCES .XX±.010 .XXX±.005 XX°±.5°
SCALE	3/8	DWG #
DESCRIPTION	1000 WATT TERMINATION	092-6133-01

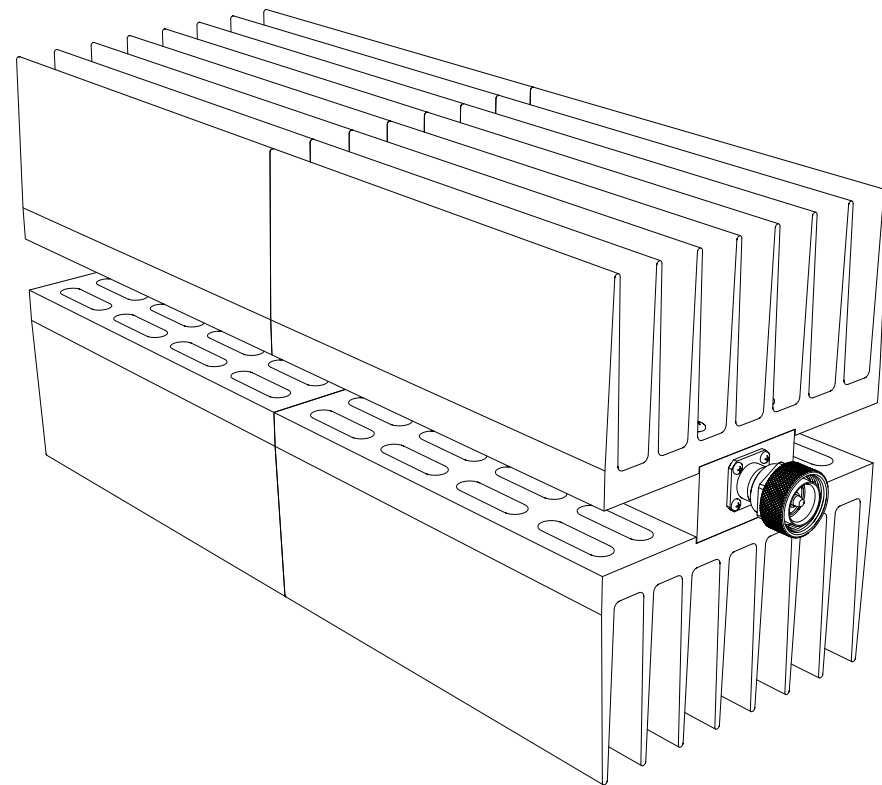
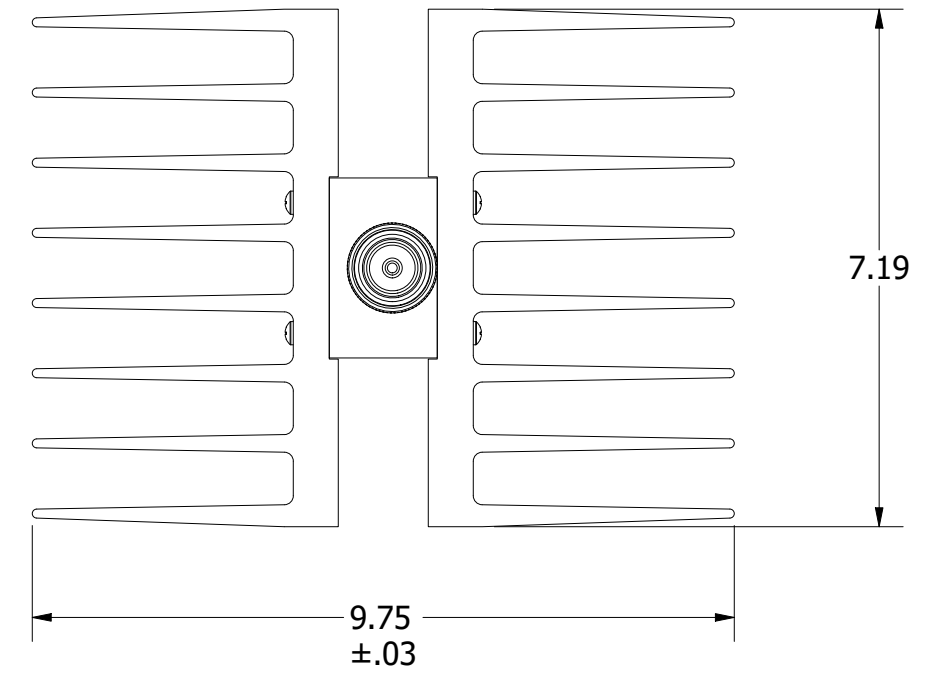
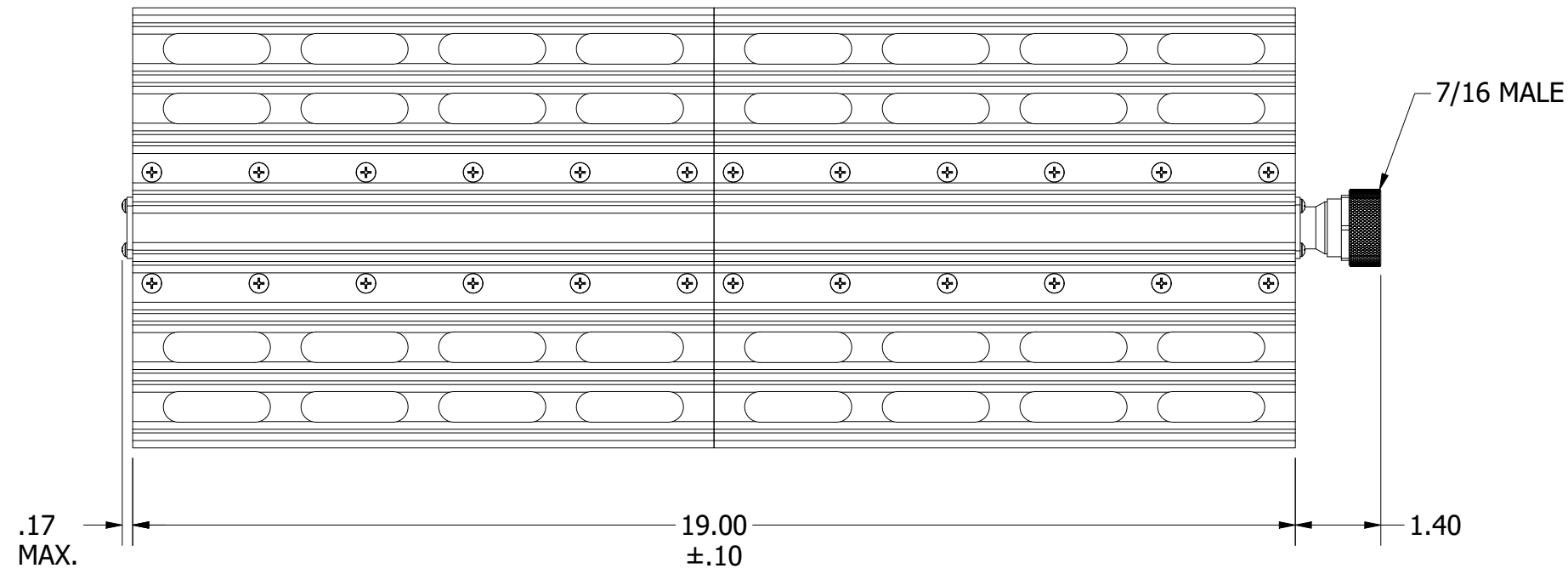

REV	ECN	DATE	BY	APPR
-	ISSUED	3-16-09	TEZ	SMR
A	24444	10-21-19	GM	TEZ

	JFW INDUSTRIES, INC. www.jfwindustries.com		PH: 317-887-1340
	MATERIAL ALUMINUM ALLOY		PROPRIETARY INFORMATION
FINISH CHEMFILM / HEATSINK: BLACK ANODIZE		ALL SURFACES ARE TO BE FREE OF BURRS, PITS & SCRATCHES	
MODEL 50T-XXX		SCALE 3/8	TOLERANCES .XX±.010 .XXX±.005 XX°±.5°
DESCRIPTION 1000 WATT TERMINATION		DWG # 092-6133-02	