

REV	ECN	DATE	BY	APPR
-	ISSUED	11-4-11	JZ	TRS
A	24444	9-12-16	GM	JZ



JFW INDUSTRIES, INC.

www.jfwindustries.com

PH: 317-887-1340

MATERIAL	BRASS	PROPRIETARY INFORMATION
FINISH	NICKEL	ALL SURFACES ARE TO BE FREE OF BURRS, PITS & SCRATCHES
MODEL	50T-XXX	TOLERANCES .XX±.010 .XXX±.005 XX°±.5°
DESCRIPTION	5 WATT TERMINATION	DWG # 092-4403-01

SCALE
x2

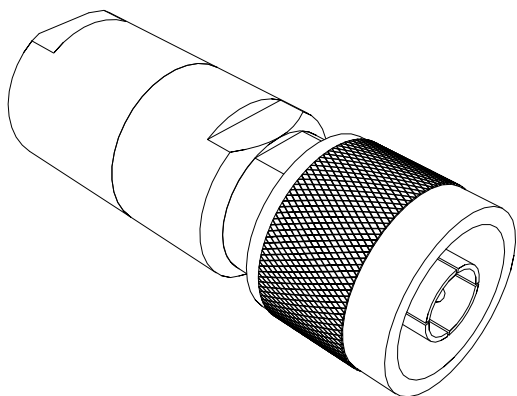
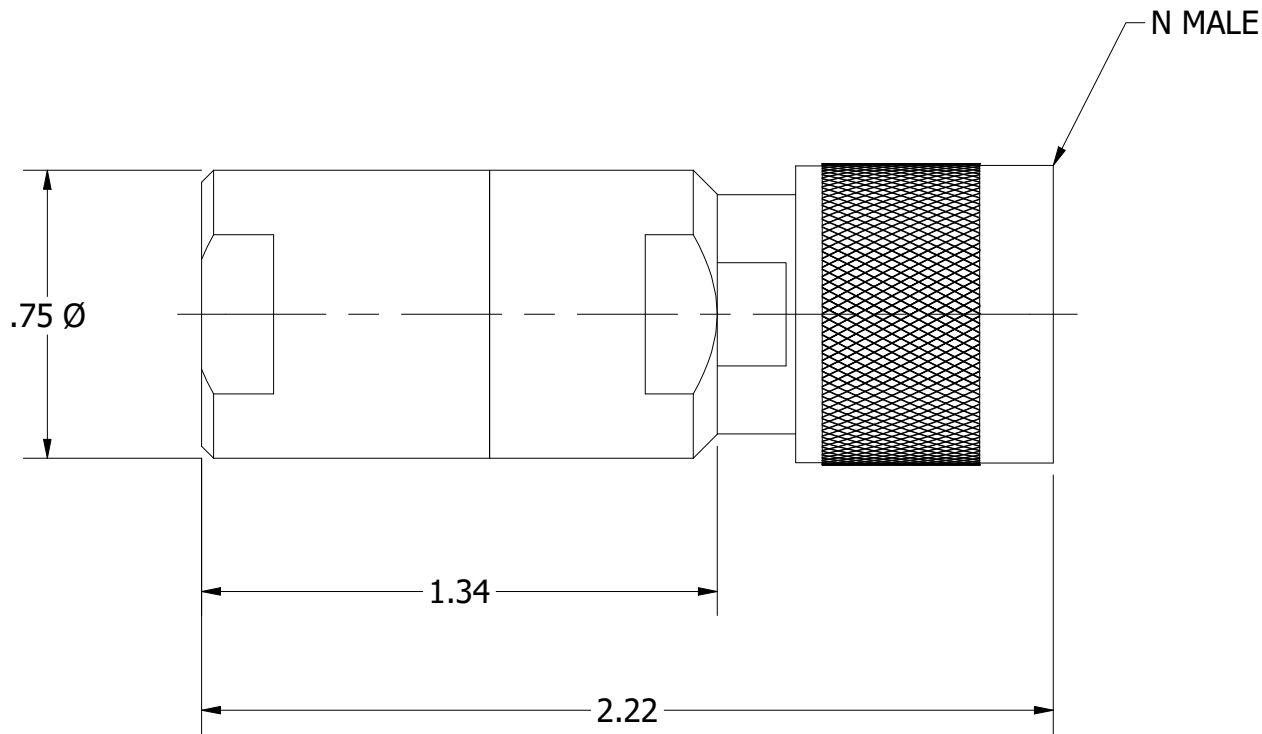

REV	ECN	DATE	BY	APPR
-	ISSUED	11-4-11	JZ	TRS
A	24444	9-12-19	GM	JZ

		<h1>JFW INDUSTRIES, INC.</h1>	
		<p>www.jfwindustries.com PH: 317-887-1340</p>	
MATERIAL		BRASS	
FINISH		NICKEL	
MODEL		50T-XXX	SCALE x2
DESCRIPTION		5 WATT TERMINATION	
		<p>PROPRIETARY INFORMATION</p> <p>ALL SURFACES ARE TO BE FREE OF BURRS, PITS & SCRATCHES</p> <p>TOLERANCES .XX±.010 .XXX±.005 XX°±.5°</p> <p>DWG # 092-4403-07</p>	