

REV	ECN	DATE	BY	APPR
-	ISSUED	4-23-03	BZ	TEZ
A	13921	3-2-07	TEZ	CLK
B	24444	11-13-15	BZ	TEZ
C	24444	9-28-16	TB	XXX



JFW INDUSTRIES, INC.

www.jfwindustries.com

PH: 317-887-1340

MATERIAL	BRASS	PROPRIETARY INFORMATION
FINISH	NICKEL	ALL SURFACES ARE TO BE FREE OF BURRS, PITS & SCRATCHES
MODEL		TOLERANCES
		.XX±.010 .XXX±.005 XX°±.5°
DESCRIPTION	N MALE TERMINATION	DWG #
		092-4208

SCALE
2X

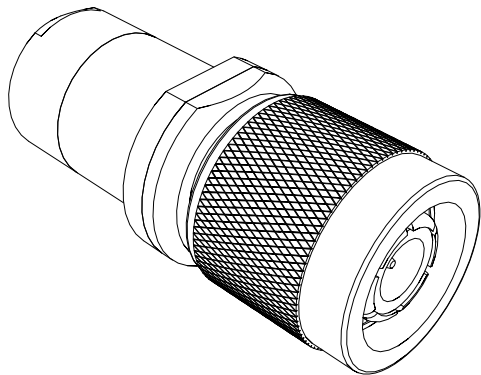
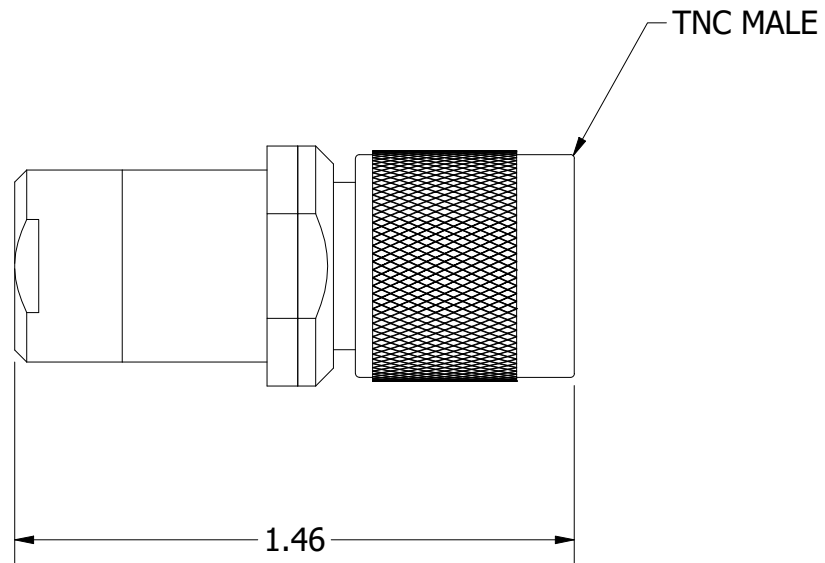

REV	ECN	DATE	BY	APPR
-	ISSUED	3-30-04	TEZ	TEZ
A	24444	9-12-19	GM	JZ



JFW INDUSTRIES, INC.

www.jfwindustries.com

PH: 317-887-1340

MATERIAL	PROPRIETARY INFORMATION	
FINISH	ALL SURFACES ARE TO BE FREE OF BURRS, PITS & SCRATCHES	
MODEL	50T-XXX	SCALE x2
DESCRIPTION	TERMINATION	TOLERANCES .XX±.010 .XXX±.005 XX°±.5° DWG #
		092-4444

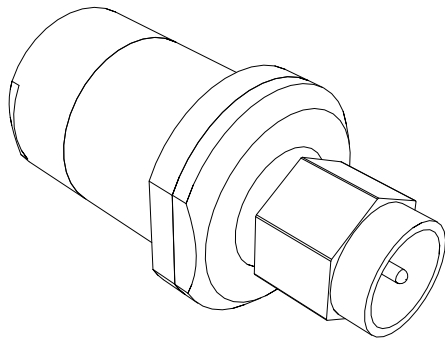
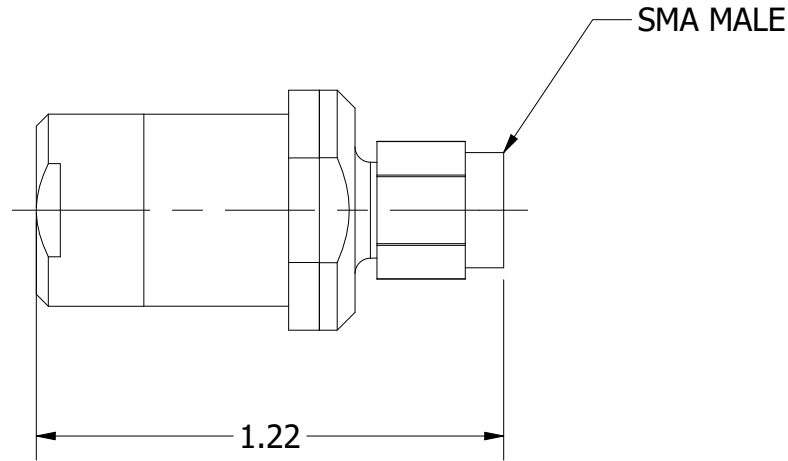

REV	ECN	DATE	BY	APPR
-	ISSUED	8-4-03	BZ	TEZ
A	24444	9-12-19	GM	TEZ



JFW INDUSTRIES, INC.

www.jfwindustries.com

PH: 317-887-1340

MATERIAL	PROPRIETARY INFORMATION	
FINISH	ALL SURFACES ARE TO BE FREE OF BURRS, PITS & SCRATCHES	
MODEL	50T-XXX	SCALE x2
DESCRIPTION	TERMINATION	TOLERANCES .XX±.010 .XXX±.005 XX°±.5° DWG # 092-4269