

F MALE

F FEMALE

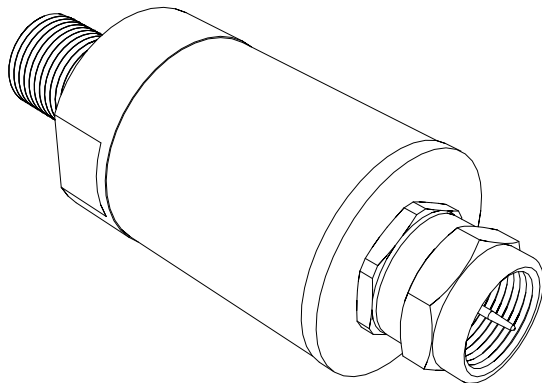

REV	ECN	DATE	BY	APPR
-	ISSUED	3-13-98	CDJ	TEZ
A	5667	5-11-98	CDJ	TEZ
B	24163	5-27-14	BZ	TEZ
C	24444	9-10-19	GM	JZ

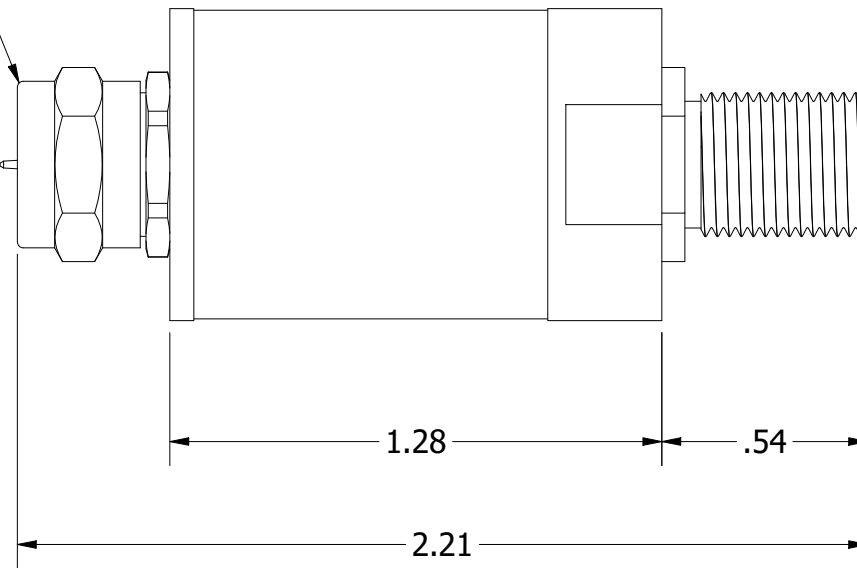

**JFW INDUSTRIES, INC.**

[www.jfwindustries.com](http://www.jfwindustries.com)

PH: 317-887-1340

MATERIAL	BRASS	PROPRIETARY INFORMATION
FINISH	NICKEL	ALL SURFACES ARE TO BE FREE OF BURRS, PITS & SCRATCHES
MODEL	SCALE x2	TOLERANCES .XX±.010 .XXX±.005 XX°±.5°
DESCRIPTION	F MALE/ F FEMALE	DWG # 092-2757

BNC MALE

BNC FEMALE

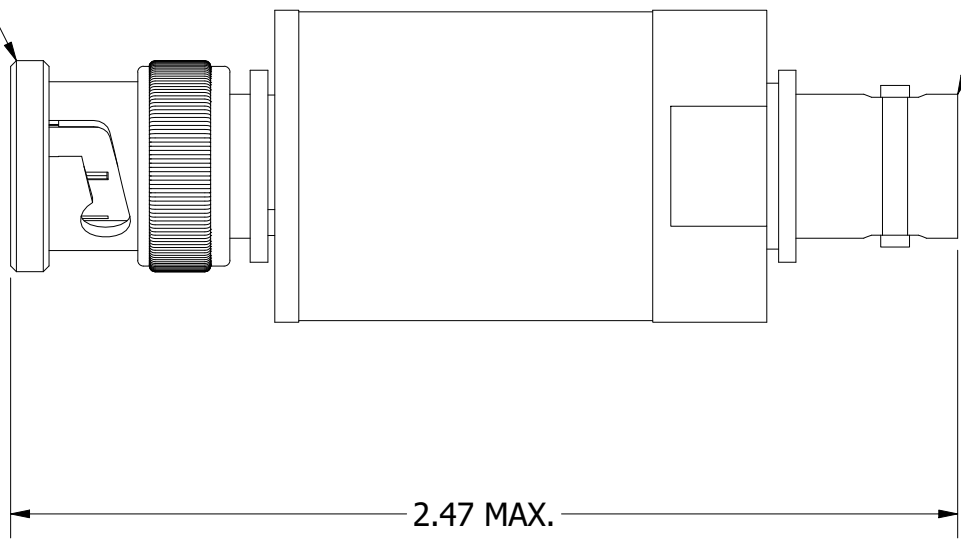

2.47 MAX.

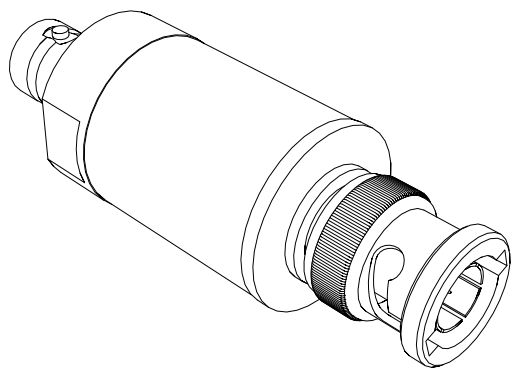

REV	ECN	DATE	BY	APPR
-	ISSUED	6-28-05	BZ	TEZ
A	12143	11-15-05	BZ	TEZ
B	20352	7-21-11	BZ	TEZ
C	23881	3-17-14	JZ	TEZ
D	25077	3-12-15	BZ	TEZ
E	24444	9-13-19	GM	JZ



**JFW INDUSTRIES, INC.**

[www.jfwindustries.com](http://www.jfwindustries.com)

PH: 317-887-1340

MATERIAL	PROPRIETARY INFORMATION
FINISH	ALL SURFACES ARE TO BE FREE OF BURRS, PITS & SCRATCHES
MODEL	TOLERANCES .XX±.010 .XXX±.005 XX°±.5°
DESCRIPTION	DWG #
BNC MALE / BNC FEMALE	092-4851

SCALE FULL