



**P** ————— Precise  
**L** ————— Low-Noise  
**D** ————— Durable  
**R** ————— Reliable  
**O** ————— Outperforming

## FEATURES

- DIELECTRIC RESONATOR
- INTERNAL CRYSTAL OSCILLATOR REFERENCE
- PHASE LOCK INDICATOR ALARM
- LOW PHASE NOISE
- MIC AND SMT FABRICATION
- LOW MICROPHONICS
- LOW POWER CONSUMPTION
- UP TO +25 dBm OUTPUT POWER
- AVAILABLE FROM 4 - 23 GHz
- OPERATING RANGE -50° TO +85°C

## APPLICATION

- SATELLITE COMMUNICATIONS
- CABLE TV LINKS (CATV)
- LOCAL AREA NETWORKS (LAN)
- GLOBAL POSITIONING SYSTEMS (GPS)
- TEST EQUIPMENT
- UP/DOWN CONVERTERS
- LMDS
- TRANSMITTER & RECEIVERS
- DIGITAL RADIOS
- MISSILE GUIDANCE

## DESCRIPTION

*PLO-4000 series Phase Locked Dielectric Resonator Oscillator (PLDRO) utilizes state of the art MIC and SMT to provide crystal stability at microwave frequencies up to 23 GHz. The low profile and rugged construction provide excellent durability against harsh environmental conditions.*

*PLO-4000 series oscillator is designed using GaAs FET or BJT amplifier with series feedback at source and Dielectric Resonator at the gate. High gain, low-noise GaAs FETs/BJTs are biased positively or negatively at the gate to ensure minimum phase-noise. The device is carefully matched for maximum power, minimum phase-noise and Voltage Standing Wave Ratio (VSWR). The oscillator is matched for maximum temperature stability and optimum negative resistance.*

*PLO-4000 series oscillator is buffered by cascaded low-noise driver and power amplifiers for minimum load pulling, maximum isolation and power. GaAs FET/BJT devices are directly attached to gold plated Kovar carriers to minimize shear effect and maximize heat sinking. Kovar carriers are mounted to the chassis to provide an efficient thermal junction and a stable structure for reduction of microphonics. To ensure oscillator stability over the full temperature range, the tuning elements are precisely designed and positioned to compensate for temperature drift by a factor of three.*

*PLO-4000 series proprietary Phase lock loop and Crystal Reference circuitry uses Surface Mount Technology. The reference frequency is multiplied and sampled to output frequency. Produced error voltage due to frequency drift is sensed by a Wein-Bridge Oscillator to provide the necessary sweep voltage to an ultra Hi-Q tuning varactor diode for the purpose of compensation and phase locking. The unique construction of phase lock loop sub-assembly provides excellent temperature stability and minimum solder joints for maximum reliability.*

*PLO-4000 series is internally voltage regulated to avoid reverse bias, frequency pushing, bias modulation and voltage transients. A phase lock indicator alarm of TTL type is provided as a feature. The PLO-3000 series are internally reference locked and factory tuned to specified frequency. Mechanical frequency adjustment is provided for optimum phase voltage setting. Buffered Reference Monitor and adjustment are standard features of this Hi-Tech oscillator. The unit may be externally locked to a reference.*

# SPECIFICATIONS

Model Number	PLO-4000-XX.XX (Where XX.XX is freq. in GHz)
Single Frequency	4.00 to 23.00 GHz
Mechanical Tuning Range	100 MHz
Power Output	+13 dBm, up to +25 dBm Optional
Load VSWR, Maximum	2.0 : 1.0
Power Requirements	+12, +15 VDC, 350 mA
Reference Input Frequency	10 MHz
Reference Power Input	Nominal +/- 6 dBm
Reference Power Input Range	-10 to +10 dBm
Frequency Stability	Same as Reference
Phase Noise	See Phase Noise Envelope (Fig. A)
Spurious	-80 dBc
Harmonics	-25 dBc
Alarm	TTL, Open Collector
Operating Temperature	-20° to +75°C Optional
Storage Temperature	-55° to +100°C
Connectors	SMA, Female
Size	2.25" x 2.25" x 1.25"
Finish	Nickel

## PHASE NOISE ENVELOPE

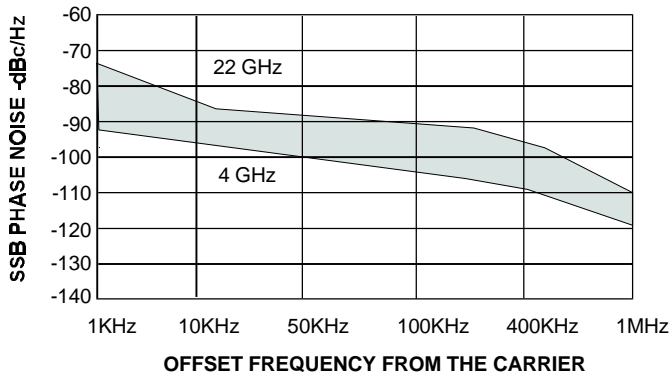

## BLOCK DIAGRAM

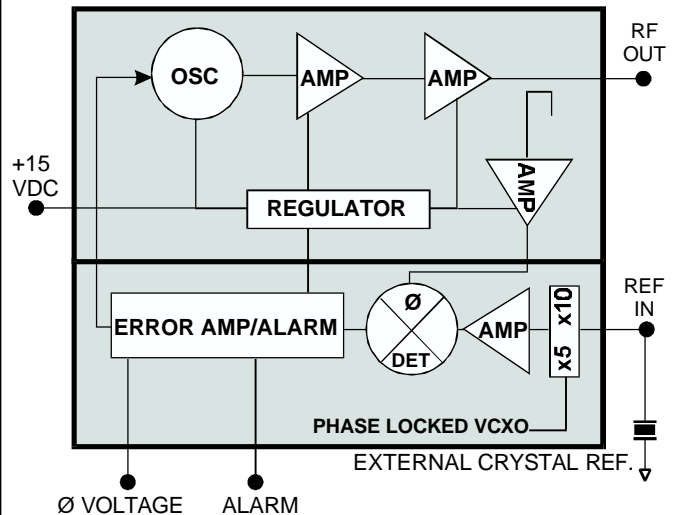

## OUTLINE DRAWING

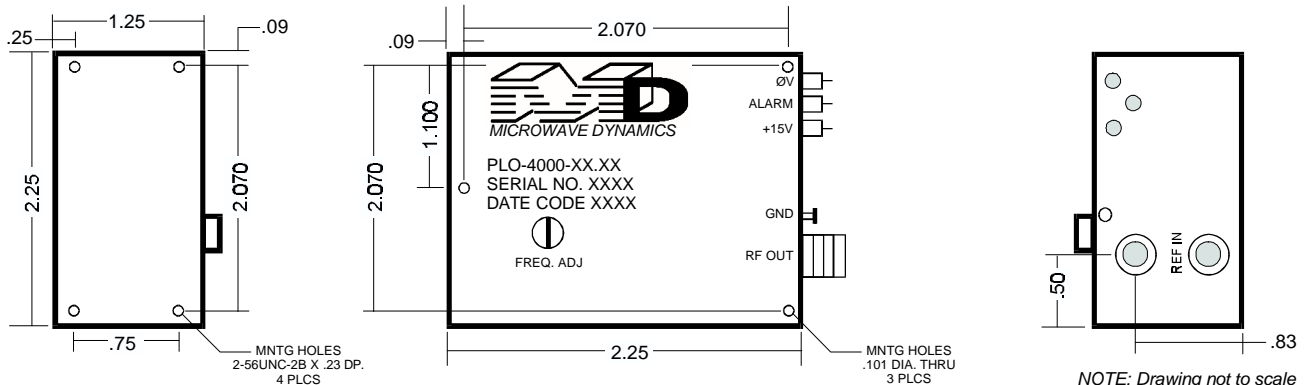

**MICROWAVE DYNAMICS, 2691 RICHTER AVE., SUITE 129, IRVINE, CA 92606 • PHONE: 949-553-8602 FAX: 949-553-8667**

**Web Page: <http://www.microwave-dynamics.com> • Email: [info@microwave-dynamics.com](mailto:info@microwave-dynamics.com)**

COPYRIGHT © 1998 MICROWAVE DYNAMICS, IRVINE CA • ORDERS ACCEPTED BY MICROWAVE DYNAMICS ARE SUBJECT TO OUR TERMS AND CONDITIONS OF SALE  
SPECIFICATIONS ARE SUBJECT TO CHANGE WITHOUT NOTICE