

MIL-STD 1553 Interface Transformers - DBIT x 7 P10(A)



- In accordance to MIL-STD 1553 A & B
- Meet all the electrical requirements of ManchesterII serial bi-phase data transmission, 1 MHz operation
- Epoxy molding in accordance with outgassing requirements of ECSS-Q-ST-70-02C
- Qualified EPPL
- Open-circuit impedance greater than 4 kΩ over 75 KHz to 1 MHz working frequency
- Frequency range 75 KHz to 1 MHz
- Operating temperature range: -55 °C up to +150 °C
- Weight: < 5 grams

Electrical Data (25°C)

ID Code	Turn ratio 1-3 : 4-8	Turn ratio 1-3 : 5-7	DCR max. [Ω] 1-3	DCR max. [Ω] 4-8	Primary Inductance (mH) min at 75 kHz-1V	Open Circuit Impedance Min (kΩ)	Operating temperature range
DBIT 1 7P10*	1,4:1	2:1	2	1,6	7 [1-3]	3	-55°C +125°C
DBIT 2 7P10*	1:1	1:0,707	2	2,2	7 [1-3]	3	-55°C +125°C
DBIT 3 7P10*	1,2:1	1,67:1	2	2	7 [1-3]	3	-55°C +125°C
DBIT 4 7P10*	1:2,5	1:1,74	1	2	7 [4-8]	3	-55°C +125°C
DBIT 5 7P10*	1:2,5	1:1,79	1	2,2	7 [4-8]	3	-55°C +125°C
DBIT 6 7P10*	2,3:1	3,2:1	2	1	7 [1-3]	3	-55°C +125°C
DBIT 7 7P10*	1,25:1	1,66:1	2	2	7 [1-3]	3	-55°C +125°C
DBIT 8 7P10*	1:2,12	1:1,5	1	2,2	7 [4-8]	3	-55°C +125°C
DBIT 9 7P10*	1:2,38	1:1,666	1	2,2	7 [1-3]	3	-55°C +125°C
DBIT 10 7P10*	1:3,0	1:2,14	1	2,2	7 [4-8]	3	-55°C +125°C
DBIT 1 7P10A	1,4:1	2:1	1,23	1,1	7 [1-3]	4	-55°C +150°C
DBIT 2 7P10A	1:1	1:0,707	1,23	1,6	7 [1-3]	4	-55°C +150°C
DBIT 3 7P10A	1,2:1	1,67:1	1,23	1,4	7 [1-3]	4	-55°C +150°C
DBIT 5 7P10A	1:2,5	1:1,79	0,6	1,4	7 [4-8]	4	-55°C +150°C
DBIT 6 7P10A	2,3:1	3,2:1	1,23	0,8	7 [1-3]	4	-55°C +150°C
DBIT 7 7P10A	1,25:1	1,66:1	1,23	1,25	7 [1-3]	4	-55°C +150°C
DBIT 8 7P10A	1:2,12	1:1,5	0,7	1,4	7 [4-8]	4	-55°C +150°C

* EPPL products - Detail Specifications MSP003

To Order

DBIT	#	7	P10	A
Range	Part 1 to 10	Case height 7	x = P10 Pins (10 mm)	New version

DBIT # 7 P10A

Notes

Common mode rejection: 45 dBmin.
 Dielectric withstanding voltage: 500Vrms.
 Insulation resistance: 1,3 - 4,8 500 V_{DC} > 1000 MΩ
 tolerance ratio ± 3%.

Typical Dimensions (mm)

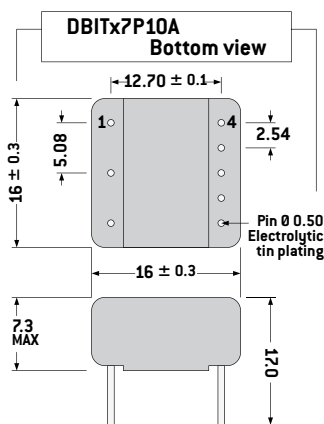

Connections

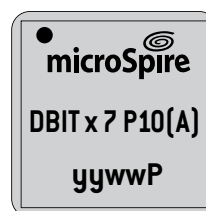
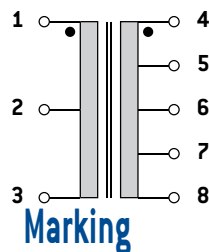

yyww :
Date code

