

- **Series 67** - pcb connections to switch and coil
- **Series 68** - pcb connections to coil and flying leads to the switch which keeps the high voltage away from the pcb
- Small size
- Up to **10 kV** stand-off, **7.5 kV** switching at **50 W** maximum
- Tungsten plated contacts ensure a long and reliable life
- **5, 12, and 24 V** coils with optional internal diode
- Encapsulated in a plastic package with internal mu-metal magnetic screen
- **Additional build options are available**
- Many benefits compared to industry standard relays (see last page)
- **1 Form A** configuration, with **1 Form C**, up to **5 kV**, coming soon

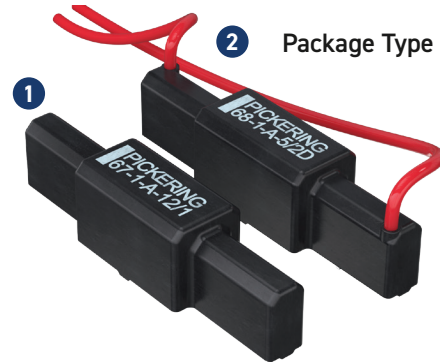

The Series 67 and 68 ranges of high voltage reed relays have similar specifications to the established Series 60/65 and 62/63 but are constructed using a leadframe in a Single-in-Line format and feature former-less coils which enables a smaller package than is usual for this type of device.

The unusual package style allows some interesting stacking possibilities (see adjacent photo) when used to construct high density multiplexers or matrices.

Other voltages can be supplied to special order as can variations in the lead length of the Series 68 type.

Switch Ratings

| 1 Form A (energize to make) |
|---|
| Stand-off 5 kV, switching up to 3.5 kV |
| Stand-off 10 kV, switching up to 7.5 kV |

Relay Packing on PCB

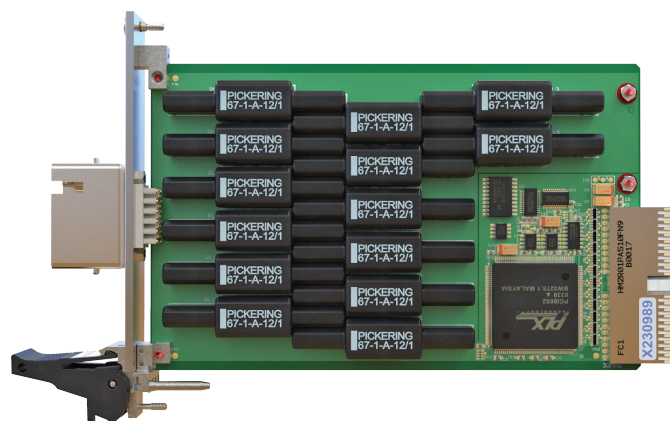

Example of Series 67 Packing Possibility

Series 67, 68 switch ratings - contact ratings for each switch type

| Switch No | Switch form | Power rating | Max. switch current | Max. carry current | Max. switching volts | Min. stand-off volts | Life expectancy ops typical (see Note ²) | Operate time inc bounce (max) | Release time |
|-----------|-------------|--------------|---------------------|--------------------|---------------------------|----------------------|--|-------------------------------|--------------|
| 1 | A | 50 W | 3 A | 5 A | 3500 (Note ¹) | 5000 | 10 ⁸ | 3 ms | 2 ms |
| 2 | A | 50 W | 3 A | 5 A | 7500 (Note ¹) | 10000 | 10 ⁸ | 3 ms | 2 ms |

Note¹: Switching Voltage

This high voltage rating is for **RESISTIVE loads only**. At these high voltages, even stray capacitance can generate very high current pulses, which can damage the contact plating causing welding of the reed switch. If there is capacitance in circuit, provision should be made to limit the surge, to within the current and power ratings of the relay.

Note²: Life Expectancy

The life of a reed relay depends upon the switch load and the end of life criteria. For example, for an 'end of life' contact resistance specification of 1Ω, switching low loads with the current less than 1 mA, or when 'cold' switching, typical life is expected to be greater than 1 x 10⁸ ops. At higher voltages and up to the maximum 50 W load (resistive), typical life is 1 x 10⁶ ops. In the event of abusive conditions, e.g. high currents due to capacitive inrushes, this figure reduces considerably. Pickering will be pleased to perform life testing with any particular load conditions.

Operating Voltages

| Coil voltage - nominal | Must operate voltage - maximum at 25°C | Must release voltage - minimum at 25°C |
|------------------------|--|--|
| 5 V | 3.75 V | 0.5 V |
| 12 V | 9 V | 1.2 V |
| 24 V | 18 V | 2.4 V |

Environmental Specification/Mechanical Characteristics

In the table below, the upper temperature limit can be extended to +125 °C if the coil drive voltage is increased to accommodate the resistance/temperature coefficient of the copper coil winding. This is approximately 0.4% per °C. This means that at 125 °C the coil drive voltage will need to be increased by approximately 40 x 0.4 = 16% to maintain the required magnetic drive level. Please contact sales@pickeringrelay.com for assistance.

| | |
|--|-------------------|
| Operating Temperature Range | -20 °C to +85 °C |
| Storage Temperature Range | -35 °C to +100 °C |
| Shock Resistance | 50 g |
| Vibration Resistance (10 - 2000 Hz) | 20 g |
| Soldering Temperature (max) (10 s max) | 270 °C |
| Washability (Proper drying process is recommended) | Fully Sealed |

Series 67 Coil data and type numbers

| Device Type | Type Number | Coil (V) | Coil resistance | Max. contact resistance (initial) | Insulation resistance (minimum) | | Capacitance (typical) (see Note) | |
|--|--------------|----------|-----------------|-----------------------------------|---------------------------------|--------------------|----------------------------------|--------------------|
| | | | | | Switch to coil | Across switch | Closed switch to coil | Across open switch |
| 1 Form A Switch No. 1 (5 kV) Package Type 1 | 67-1-A-5/1D | 5 | 40 Ω | 0.12 Ω | 10 ¹² Ω | 10 ¹² Ω | 3 pF | 0.15 pF |
| | 67-1-A-12/1D | 12 | 150 Ω | | | | | |
| | 67-1-A-24/1D | 24 | 600 Ω | | | | | |
| 1 Form A Switch No. 2 (10 kV) Package Type 1 | 67-1-A-5/2D | 5 | 40 Ω | 0.12 Ω | 10 ¹² Ω | 10 ¹² Ω | 3 pF | 0.15 pF |
| | 67-1-A-12/2D | 12 | 150 Ω | | | | | |
| | 67-1-A-24/2D | 24 | 600 Ω | | | | | |

When an internal diode is required, the suffix D is added to the part number as shown in the table.

Note: Capacitance across open switch

This is measured with all other component leads connected to the guard terminal of the measuring bridge.

Series 68 Coil data and type numbers

| Device Type | Type Number | Coil (V) | Coil resistance | Max. contact resistance (initial) | Insulation resistance (minimum) | | Capacitance (typical) (see Note) | |
|--|--------------|----------|-----------------|-----------------------------------|---------------------------------|--------------------|----------------------------------|--------------------|
| | | | | | Switch to coil | Across switch | Closed switch to coil | Across open switch |
| 1 Form A Switch No. 1 (5 kV) Package Type 2 | 68-1-A-5/1D | 5 | 40 Ω | 0.12 Ω | 10 ¹² Ω | 10 ¹² Ω | 3 pF | 0.15 pF |
| | 68-1-A-12/1D | 12 | 150 Ω | | | | | |
| | 68-1-A-24/1D | 24 | 600 Ω | | | | | |
| 1 Form A Switch No. 2 (10 kV) Package Type 2 | 68-1-A-5/2D | 5 | 40 Ω | 0.12 Ω | 10 ¹² Ω | 10 ¹² Ω | 3 pF | 0.15 pF |
| | 68-1-A-12/2D | 12 | 150 Ω | | | | | |
| | 68-1-A-24/2D | 24 | 600 Ω | | | | | |

When an internal diode is required, the suffix D is added to the part number as shown in the table.

Note: Capacitance across open switch

This is measured with all other component leads connected to the guard terminal of the measuring bridge.

The technical information shown in this data sheet could contain inaccuracies or typographical errors. This information may be periodically changed or updated and these changes will be included in future versions of this data sheet.

For different values, latest specifications and product details, please contact you local Pickering sales office.

For **FREE** evaluation samples go to: pickeringrelay.com/samples

Pin Configuration, Weights and Dimensional Data (dimensions in inches, millimeters in brackets)

Package Type 1

Series 67

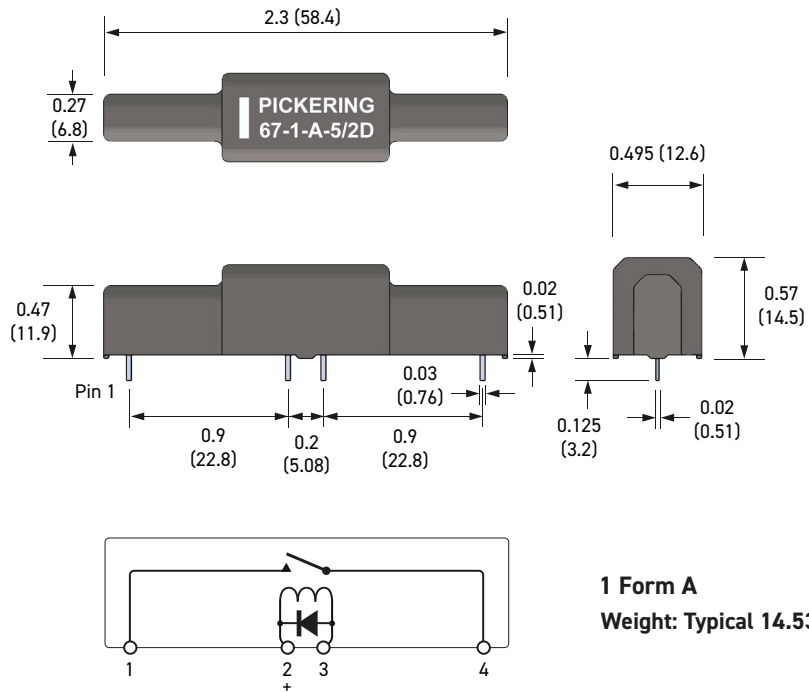

Package Type 2

Series 68

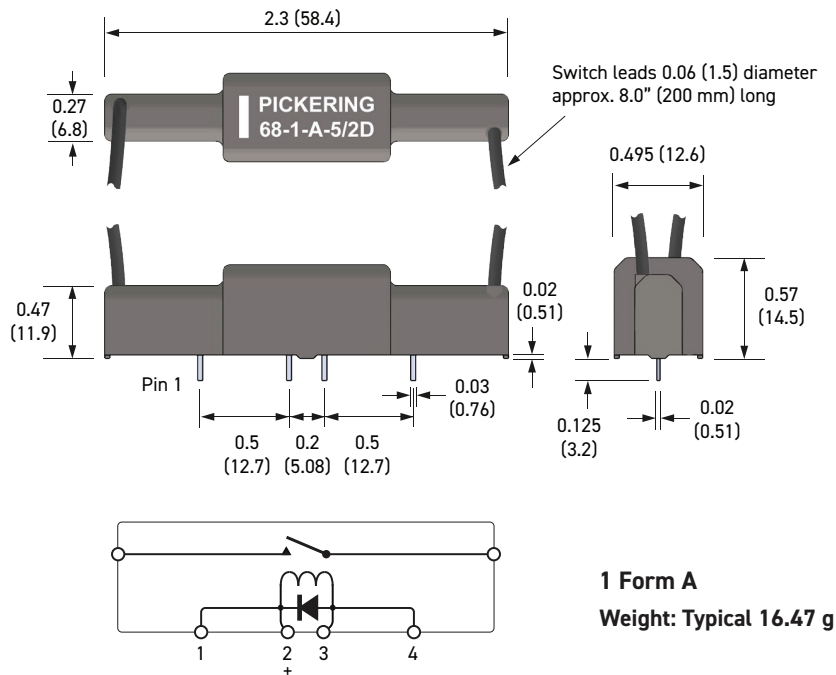

Important: Where the optional internal diode is fitted or for all Form B types, the correct coil polarity must be observed, as shown by the + symbol on the schematics.

Similar Relays Comparison

If the Series 67 and 68 are unsuitable for your application, Pickering also manufactures four other series of reed relays with similar characteristics, but in different package sizes.

| Series Name | | 60-1-A | | | 60-1-B | | | 65-1-A | | 65-1-B | | 67-1-A | | 68-1-A | | 62-1-A | | 62-1-B | | 63-1-A | | | 63-1-B | | |
|-----------------------------------|----------------|---|-------|-------|---|-------|------|---|------|---|------|--|------|---|------|---|------|---|------|---|--------------|-------|---|------|-------|
| Physical Outline | |  | | |  | | |  | |  | |  | |  | |  | |  | |  | | |  | | |
| Depth | mm (inches) | 16.0 (0.63) | | | 16.0 (0.63) | | | 16.0 (0.63) | | 12.6 (0.495) | | 12.6 (0.495) | | 19.05 (0.75) | | 19.05 (0.75) | | 19.05 (0.75) | | | 19.05 (0.75) | | | | |
| Width | | 57.9 (2.28) | | | 57.9 (2.28) | | | 57.9 (2.28) | | 58.4 (2.3) | | 58.4 (2.3) | | 63.5 (2.5) | | 63.5 (2.5) | | 63.5 (2.5) | | | 63.5 (2.5) | | | | |
| Height | | 18.0 (0.71) | | | 18.0 (0.71) | | | 18.0 (0.71) | | 14.5 (0.57) | | 14.5 (0.57) | | 21.3 (0.84) | | 21.3 (0.84) | | 21.3 (0.84) | | | 21.3 (0.84) | | | | |
| Package Volume (mm ³) | | 16676 | | | 16676 | | | 16676 | | 9543 | | 9543 | | 25767 | | 25767 | | 25767 | | | 25767 | | | | |
| Typical Weights (g) | | 28.43 | | | 31.83 | | | 23.99 | | 31.65 | | 14.53 | | 16.47 | | 44.16 | | 44.69 | | 45.47 | | | 44.69 | | |
| Contact Configuration | | 1-A (SPST) | | | 1-B (SPNC) | | | 1-A (SPST) | | 1-B (SPNC) | | 1-A (SPST) | | 1-A (SPST) | | 1-A (SPST) | | 1-B (SPNC) | | 1-A (SPST) | | | 1-B (SPNC) | | |
| Reed Switch Type | | Dry | | | Dry | | | Dry | | Dry | | Dry | | Dry | | Dry | | Dry | | Dry | | | Dry | | |
| Stand-off Voltage (V) | | 5000 | 10000 | 15000 | 5000 | 10000 | 5000 | 10000 | 5000 | 10000 | 5000 | 10000 | 5000 | 10000 | 5000 | 10000 | 5000 | 10000 | 5000 | 10000 | 5000 | 10000 | 15000 | 5000 | 10000 |
| Switching Voltage (V) | | 3500 | 7500 | 12500 | 3500 | 7500 | 3500 | 7500 | 3500 | 7500 | 3500 | 7500 | 3500 | 7500 | 3500 | 7500 | 3500 | 7500 | 3500 | 7500 | 3500 | 7500 | 12500 | 3500 | 7500 |
| Switching Current (A) | | 3 | | | 3 | | | 3 | | 3 | | 3 | | 3 | | 3 | | 3 | | | 3 | | | | |
| Carry Current (A) | | 5 | | | 5 | | | 5 | | 5 | | 5 | | 5 | | 5 | | 5 | | | 5 | | | | |
| Switch Power (W) | | 50 | | | 50 | | | 50 | | 50 | | 50 | | 50 | | 50 | | 50 | | | 50 | | | | |

Reed Relay Selection Tool

Because Pickering offer the largest range of high-quality reed relays, sometimes it can be difficult to find the right reed relay you require. That is why we created the Reed Relay Selector, this tool will help you narrow down our offering to get you the correct reed relay for your application. To try the tool today go to: pickeringrelay.com/reed-relay-selector-tool

Standard Build Options

The Series 67 and 68 Reed Relays are available with a number of standard build options to tailor them to your specific application. These options are detailed in the table below. If you decide to go ahead and specify one, or more, of these options you will be allocated a unique part number suffix.

| Mechanical Build Options | Electrical Build Options |
|---|--|
| Special pin configurations or pin lengths | Different coil resistance |
| Special print with customer's own part number or logo | Different stand-off or switching voltage |
| Custom packaging | Operate or de-operate time |
| Equivalents to competitors discontinued parts | Pulse capability |
| | Enhanced specifications |
| | Equivalents to competitors discontinued parts |
| | Non-standard coil voltages and resistance figures |
| | Special Life testing under customer's specific load conditions |
| | Specific environmental requirements |

Customization

If your specific requirements are not met by standard relay, or any of the standard build options, please speak to us to discuss producing a customized reed relay to service your specific application: pickeringrelay.com/contact

3D Models

Interactive 3D models of the complete range of Pickering relay products in STEP, IGS and SLDPRN formats can be downloaded from the website: pickeringrelay.com/3d-models

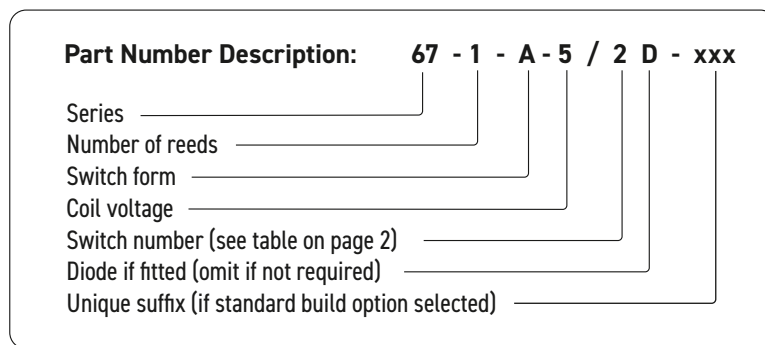

Help

If you need any technical advice or other help, please do not hesitate to contact our Technical Sales Department. We will always be pleased to discuss Pickering relays with you. email: techsales@pickeringrelay.com

Contact Us

UK Headquarters - email: sales@pickeringrelay.com | Tel. +44 1255 428141

USA - email: ussales@pickeringrelay.com | Tel. +1 781 897 1710

Germany - email: desales@pickeringtest.com | Tel. +49 89 125 953 160

France - email: frsales@pickeringtest.com | Tel. +33 9 72 58 77 00

Nordic - email: ndsales@pickeringtest.com | Tel. +46 340 69 06 69









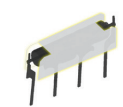
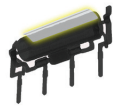

Czech Republic: czsales@pickeringtest.com | Tel. +420 558-987-613

China - email: chinasales@pickeringtest.com | Tel. +86 4008 799 765

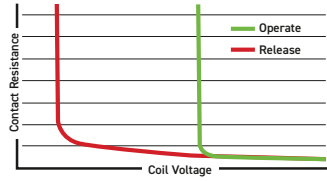
For a full list of agents, distributors and representatives visit: pickeringrelay.com/agents

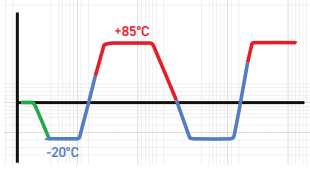

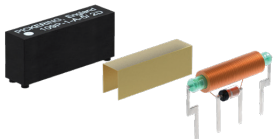
10 Key Benefits of Pickering Reed Relays

| Key Benefit | Pickering Reed Relays | Typical Industry Reed Relays | |
|---|---|--|--|
| 1 Instrumentation Grade Reed Switches | Instrumentation Grade Reed Switches with vacuum sputtered Ruthenium plating to ensure stable, long life up to 5x10E9 operations. | Often low grade Reed Switches with electroplated Rhodium plating resulting in higher, less stable contact resistance. |  |
| 2 Formerless Coil Construction | Formerless coil construction increases the coil winding volume, maximizing magnetic efficiency, allowing the use of less sensitive reed switches resulting in optimal switching action and extended lifetime at operational extremes. | Use of bobbins decreases the coil winding volume, resulting in having less magnetic drive and a need to use more sensitive reed switches which are inherently less stable with greatly reduced restoring forces. |   Pickering former-less coil Typical industry coil wound on bobbin |
| 3 Magnetic Screening | Mu-metal magnetic screening (either external or internal), enables ultra-high PCB side-by-side packing densities with minimal magnetic interaction, saving significant cost and space. Pickering Mu-Metal magnetic screen - interaction approx. 5% | Lower cost reed relays have minimal or no magnetic screening, resulting in magnetic interaction issues causing changes in operating and release voltages, timing and contact resistance, causing switches to not operate at their nominal voltages. Typical industry screen - interaction approx. 30% |   X-Ray of Pickering mu-metal magnetic screen X-Ray of typical industry magnetic screen |
| 4 SoftCenter™ Technology | SoftCenter™ technology, provides maximum cushioned protection of the reed switch, minimising internal lifetime stresses and extending the working life and contact stability. | Rigid hard moulded reed relays result in significant stresses to the glass reed switch which can cause the switch blades to deflect or misalign leading to changes in the operating characteristics, contact resistance stability and operating lifetime. |   Pickering soft center protection of the reed switch Typical industry thermo-setting hard moulded protection of the reed switch |
| 5 100% Dynamic Testing | 100% testing for all operating parameters including dynamic contact wave-shape analysis with full data scrutiny to maintain consistency. | Simple dc testing or just batch testing which may result in non-operational devices being supplied. | Dynamic Contact Resistance Test  |
| 6 100% Inspection at Every Stage of Manufacturing | Inspection at every stage of manufacturing maintaining high levels of quality. | Often limited batch inspection. |  |
| 7 100% Thermal Cycling | Stress testing of the manufacturing processes, from -20°C to +85°C to -20°C, repeated 3 times. | Rarely included resulting in field failures. |  |
| 8 Flexible Manufacturing Process | Flexible manufacturing processes allow quick-turn manufacturing of small batches. | Mass production: Usually large batch sizes and with no quick-turn manufacturing. |  |
| 9 Custom Reed Relays | Our reed relays can be customized easily, e.g. special pin configurations, enhanced specifications, non-standard coil or resistance figures, special life testing, low capacitance, and more. | Limited ability to customize. |  |
| 10 Product Longevity | Pickering are committed to product longevity; our reed relays are manufactured and supported for more than 25 years from introduction, typically much longer. | Most other manufacturers discontinue parts when they reach a low sales threshold; costing purchasing and R&D a great deal of unnecessary time and money to redesign and maintain supply. |  |

For more information go to: pickeringrelay.com/10-key-benefits