

ALL DESIGN, OPERATIVE AND PROCESS DATA PERTAINING TO THE ARTICLE SHOWN ON THIS SHEET IS THE PROPERTY OF POLYPHASER CORPORATION. THE INFORMATION IS NOT TO BE COPIED, REPRODUCED, REVEALED TO OR APPROPRIATED BY OTHERS WITHOUT THE EXPRESS WRITTEN CONSENT OF POLYPHASER CORPORATION.

REVISIONS				
REV LTR	DATE	ENG	MKTG	Q.A.
A	09/06/00	PS	PH	RM

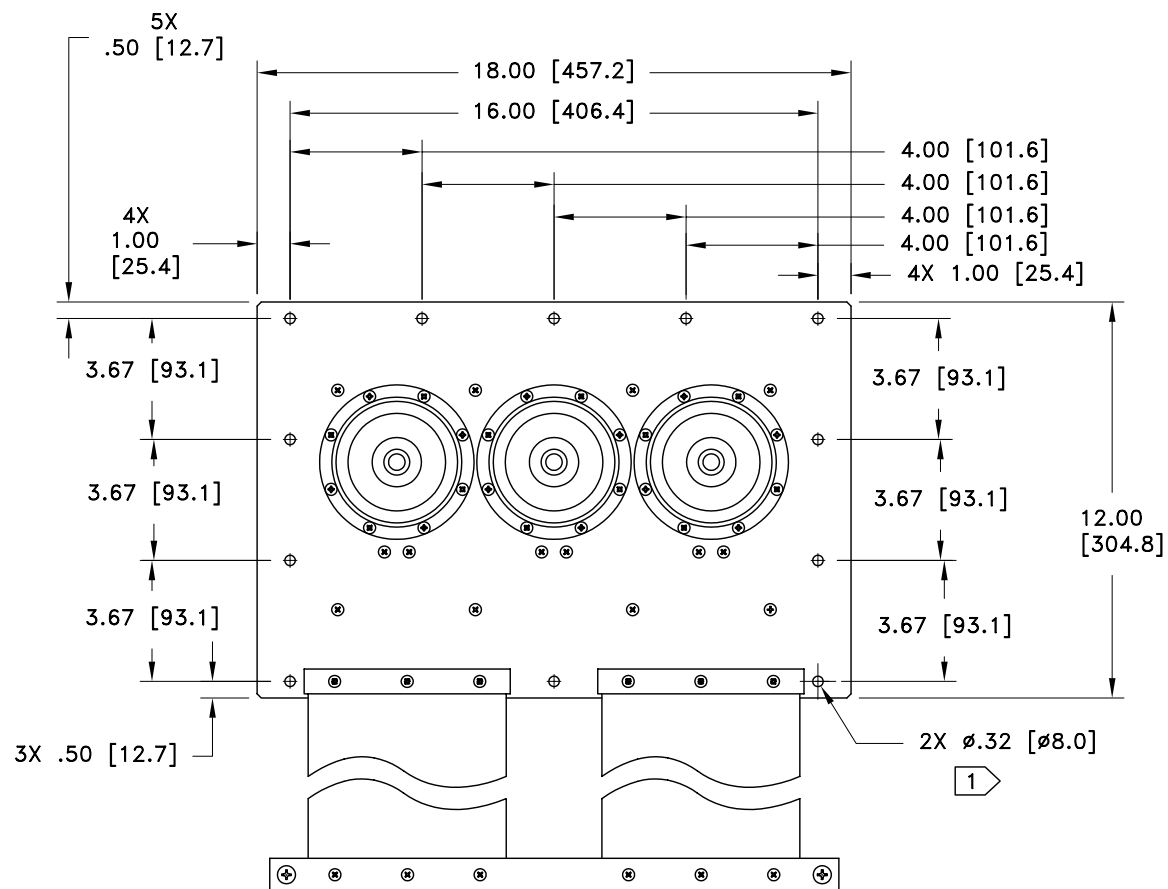
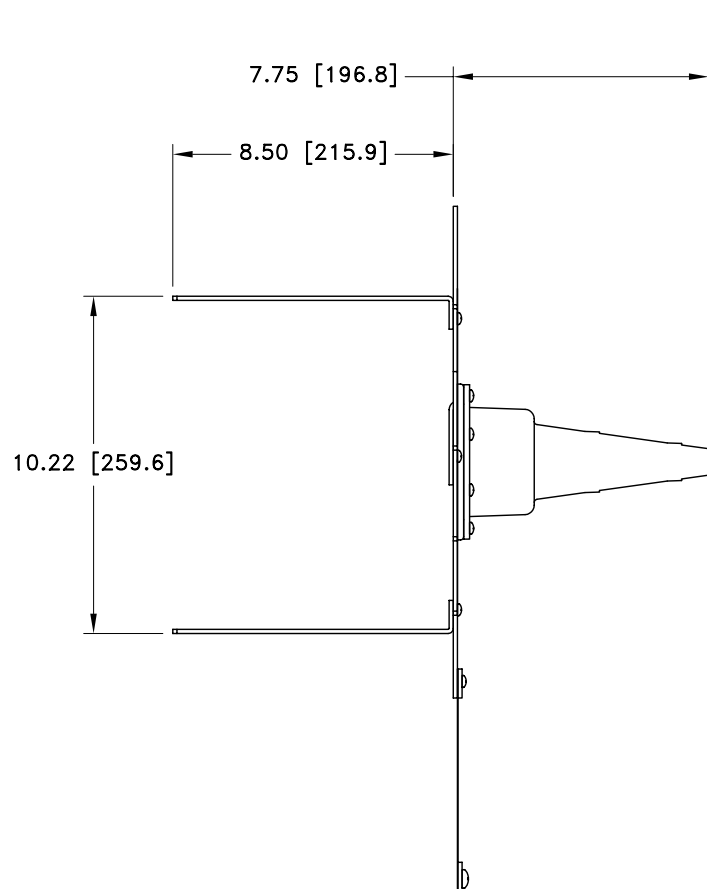

SPECIFICATIONS
MATERIAL: C110 HALF HARD COPPER
HARDWARE: STAINLESS STEEL AND BRASS
BOOTS: UV & WEATHER RESISTANT EPDM RUBBER
COAX DIAMETER: UP TO 3.125" DIAMETER

1 MATCH DRILL MOUNTING HOLES.

CUSTOMER APPROVAL: _____ DATE: _____
 ALL DIMENSIONS SHOWN ABOVE ARE FOR REFERENCE ONLY.

DRAFTER R. DUNNING	DATE 05/19/94	PolyPhaser® P.O. BOX 9000, MINDEN, NY 89423-9000 (775) 782-2511 FAX (775) 782-4478 DWG NO/PART NO/DESCRIPTION 3PEEP CUSTOMER PRINT			
MECH ENGINEER - - - -	DATE - - - -				
ELEC ENGINEER J. JONES	DATE 05/19/94				
MARKETING - - - -	DATE - - - -				
QUALITY DEPT R. MATHEUS	DATE 05/19/94	CAGE CODE 61114	FILE NAME -C1	SCALE 1/6	SHEET 1 OF 1