

ALL DESIGN, OPERATIVE AND PROCESS DATA PERTAINING TO THE ARTICLE SHOWN ON THIS SHEET IS THE PROPERTY OF POLYPHASER CORPORATION. THE INFORMATION IS NOT TO BE COPIED, REPRODUCED, REVEALED TO OR APPROPRIATED BY OTHERS WITHOUT THE EXPRESS WRITTEN CONSENT OF POLYPHASER CORPORATION.

REVISIONS

REV LTR	DATE	ENG	MKTG	Q.A.
A	05/07/01 ^{IB}	JJ	PH	RM
B	11/27/01 ^{SH}	RCD	TE	RM
C	06/04/02 ^{SH}	JJ	PH	RM
D	07/02/03 ^{SH}	RD	SD	LJ

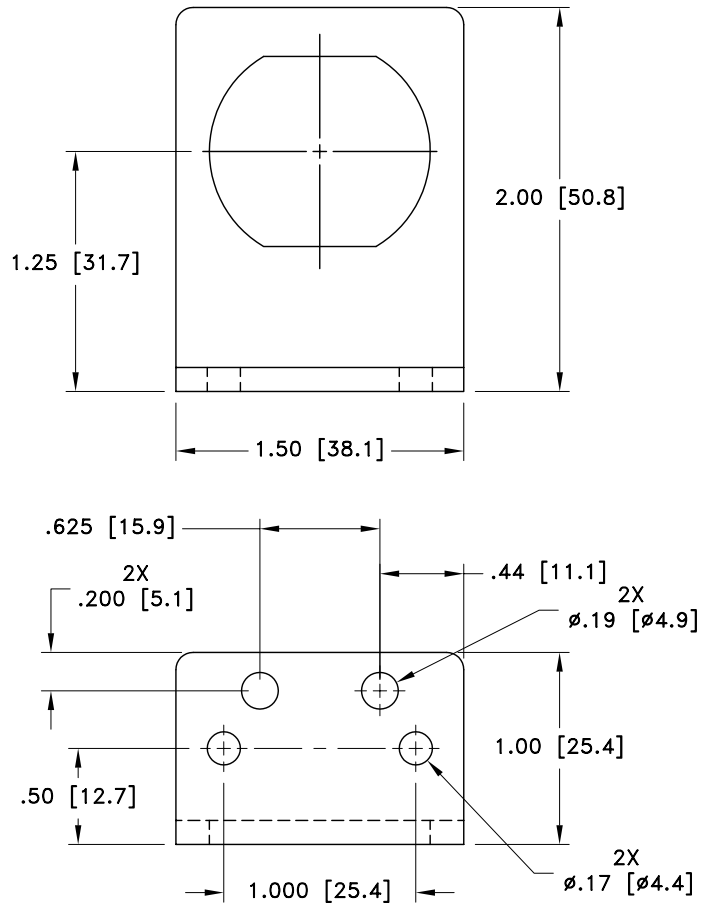

MOUNTING PATTERN

ITEM	DESCRIPTION	QTY
1	8-32 x 1/2 PHIL SCREW	2
2	#8 INT. TOOTH LOCKWASHER	2
3	8-32 HEX NUT	2
4	BULKHEAD TO FLANGE ADAPTOR	1
5	10-32 X 1/2 SLOTTED SCREW	2
6	10-32 HEX NUT	2
7	#10 INTERNAL TOOTH LOCKWASHER	2

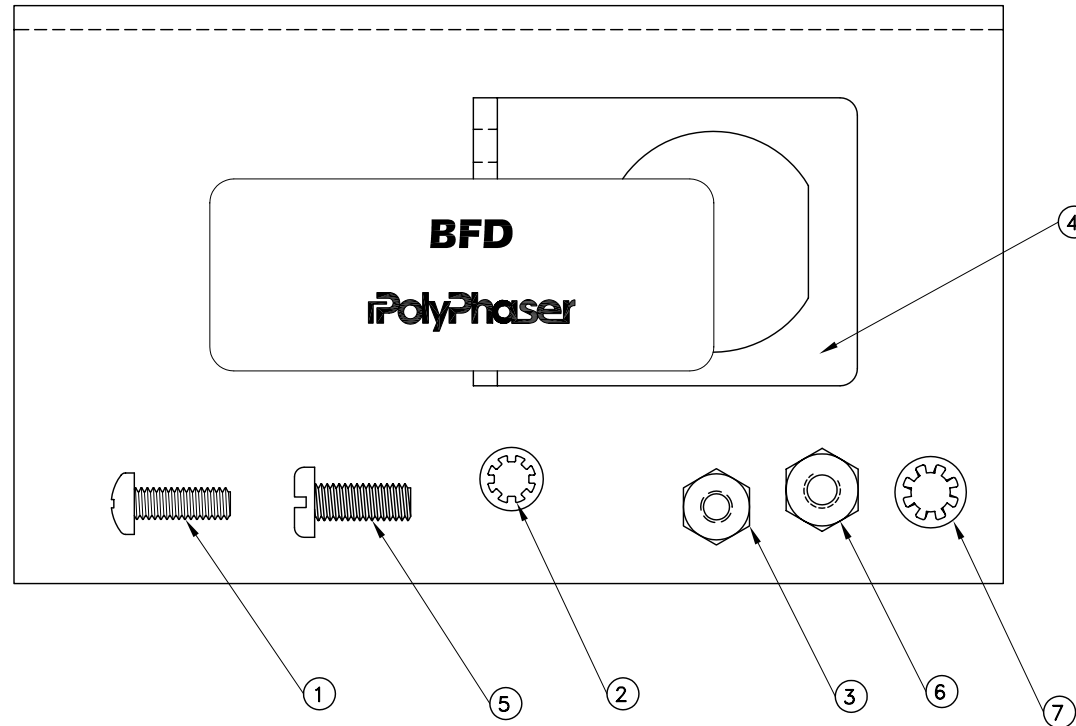

CUSTOMER APPROVAL: _____ DATE: _____

ALL DIMENSIONS SHOWN ABOVE ARE FOR REFERENCE ONLY.

DRAFTER S. HALL	DATE 04/06/99	 P.O. BOX 9000 MINDEN, NV 89423 TEL: 775-782-2511 FAX: 775-782-4476 DWG NO/PART NO/DESCRIPTION BFD BULKHEAD TO FLANGE FOR DIN'S CUSTOMER PRINT			
MECH ENGINEER R. DUNNING	DATE 04/06/99				
ELEC ENGINEER K. BARTEL	DATE 04/06/99				
MARKETING T. FRALEY	DATE 04/06/99				
QUALITY DEPT R. MATHEUS	DATE 04/06/99	CAGE CODE 61114	FILE NAME -C1	SCALE 1/1	SHEET 1 OF 1