

ALL DESIGN, OPERATIVE AND PROCESS DATA PERTAINING TO THE ARTICLE SHOWN ON THIS SHEET IS THE PROPERTY OF POLYPHASER CORPORATION. THE INFORMATION IS NOT TO BE COPIED, REPRODUCED, REVEALED TO OR APPROPRIATED BY OTHERS WITHOUT THE EXPRESS WRITTEN CONSENT OF POLYPHASER CORPORATION.

MAXIMUM CHARACTERISTICS

APPLICATION:
 FLANGE MOUNT
 FREQUENCY RANGE:
 1.5MHz TO 400MHz
 VSWR:
 ≤1.2:1 1.5MHz TO 2MHz
 ≤1.1:1 2MHz TO 400MHz
 INSERTION LOSS:
 ≤0.1dB OVER FREQUENCY RANGE
 POWER:
 HF 2kW, VHF 375W, UHF 125W
 THROUGHPUT ENERGY:
 ≤10mJ 6kV/3kA 8/20μs WAVEFORM
 OPERATING TEMPERATURE:
 -40°C TO +50°C
 STORAGE TEMPERATURE:
 -40°C TO +85°C
 VIBRATION:
 1G AT 5Hz TO 100Hz

REVISIONS

REV LTR	DATE	ENG	MKTG	Q.A.
A	07/14/99 ^{SH}	M.M	T.M	R.M
B	01/15/01 ^{SH}	KCB	PH	RM
C	12/20/02 ^{SH}	KCB	SD	LJ

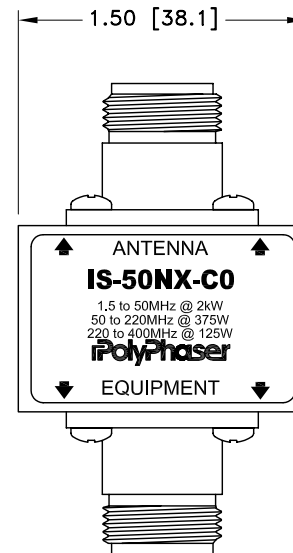
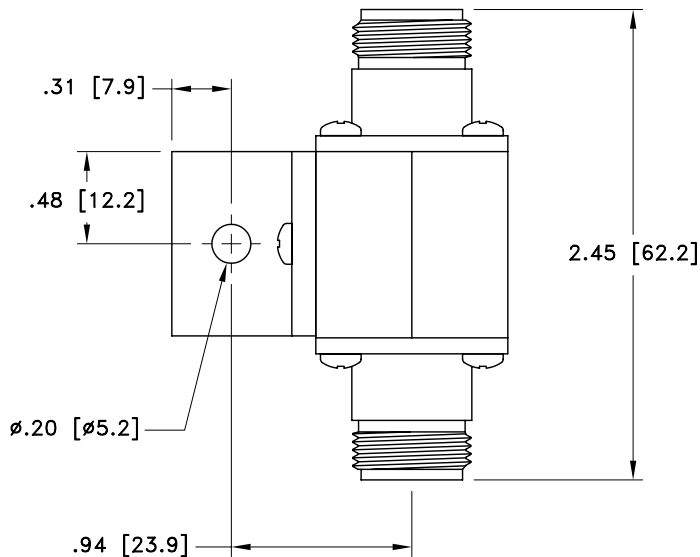
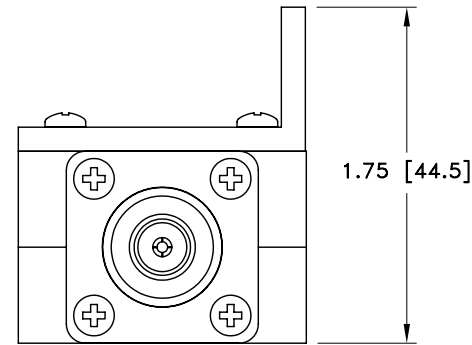

CUSTOMER APPROVAL: _____ DATE: _____

ALL DIMENSIONS SHOWN ABOVE ARE FOR REFERENCE ONLY.

DRAFTER J. CALLISTER	DATE 02/24/98	 P.O. BOX 9000 MINDEN, NV 89423 TEL: 775-782-2511 FAX: 775-782-4476 IS-50NX-CO CUSTOMER PRINT			
MECH ENGINEER O. AKDAG	DATE 03/20/98				
ELEC ENGINEER K. BARTEL	DATE 03/16/98				
MARKETING - - - -	DATE - - - -				
QUALITY DEPT R. MATHEUS	DATE 03/20/98	CAGE CODE 61114	FILE NAME -C1	SCALE 1/1	SHEET 1 OF 1