

ALL DESIGN, OPERATIVE AND PROCESS DATA PERTAINING TO THE ARTICLE SHOWN ON THIS SHEET IS THE PROPERTY OF POLYPHASER CORPORATION. THE INFORMATION IS NOT TO BE COPIED, REPRODUCED, REVEALED TO OR APPROPRIATED BY OTHERS WITHOUT THE EXPRESS WRITTEN CONSENT OF POLYPHASER CORPORATION.

REVISIONS

REV LTR	DATE	ENG	MKTG	Q.A.
A	07/16/99 ^{SH}	M.M	R.J	J.B
B	01/16/01 ^{SH}	KCB	PH	RM
C	05/02/01 ^{IB}	KCB	PH	RM
D	01/02/03 ^{SH}	LC	PH	LJ

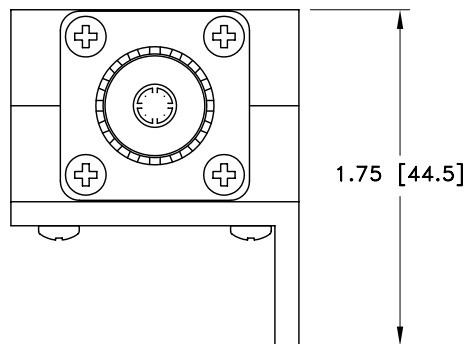
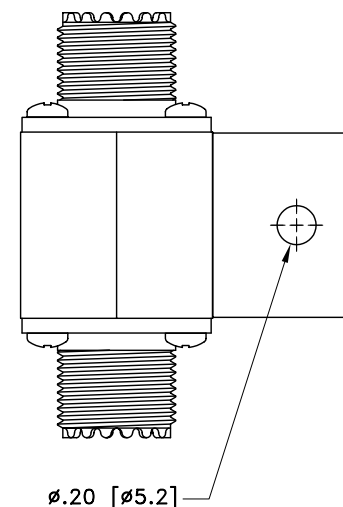
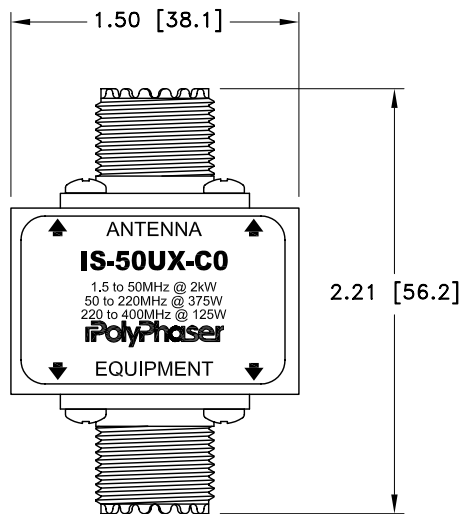
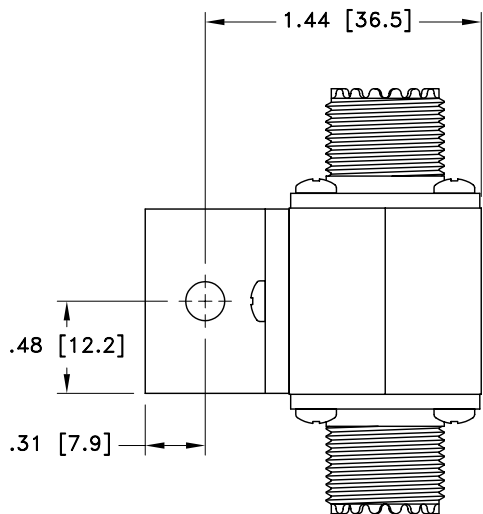

MAXIMUM CHARACTERISTICS

APPLICATION:
FLANGE MOUNT
FREQUENCY RANGE:
1.5MHz TO 400MHz
SURGE:
50kA IEC 1000-4-5 8/20µs WAVEFORM 500JOULES
TURN ON:
600Vdc±20% 2.5ns FOR 2kV
VSWR:
≤1.2:1 @ 1.5MHz TO 400MHz
INSERTION LOSS:
≤0.1dB OVER FREQUENCY RANGE
MAX POWER:
HF 2kW, VHF 375W, UHF 125W
THROUGHPUT ENERGY:
≤10mJ (UHF CONNECTOR/SURFACE)
OPERATING TEMPERATURE:
+50°C
STORAGE TEMPERATURE:
-45°C TO +85°C
RELATIVE HUMIDITY:
90% AT 40°C
VIBRATION:
1G AT 5Hz TO 100Hz

CUSTOMER APPROVAL: _____ DATE: _____

ALL DIMENSIONS SHOWN ABOVE ARE FOR REFERENCE ONLY.

DRAFTER J. CALLISTER	DATE 03/19/98	 P.O. BOX 9000 MINDEN, NV 89423 TEL: 775-782-2511 FAX: 775-782-4476 IS-50UX-CO CUSTOMER PRINT			
MECH ENGINEER O. AKDAG	DATE 04/01/98				
ELEC ENGINEER K. BARTEL	DATE 03/23/98				
MARKETING - - - -	DATE - - - -				
QUALITY DEPT R. MATHEUS	DATE 03/27/98	CAGE CODE 61114	FILE NAME -C1	SCALE 1/1	SHEET 1 OF 1