

ALL DESIGN, OPERATIVE AND PROCESS DATA PERTAINING TO THE ARTICLE SHOWN ON THIS SHEET IS THE PROPERTY OF POLYPHASER CORPORATION. THE INFORMATION IS NOT TO BE COPIED, REPRODUCED, REVEALED TO OR APPROPRIATED BY OTHERS WITHOUT THE EXPRESS WRITTEN CONSENT OF POLYPHASER CORPORATION.

REVISIONS

REV LTR	DATE	ENG	MKTG	Q.A.
A	09/02/99 ^{SH}	M.M	T.M	R.M
B	01/17/01 ^{SH}	KCB	PH	RM
C	05/02/01 ^{IB}	RCD	PH	RM

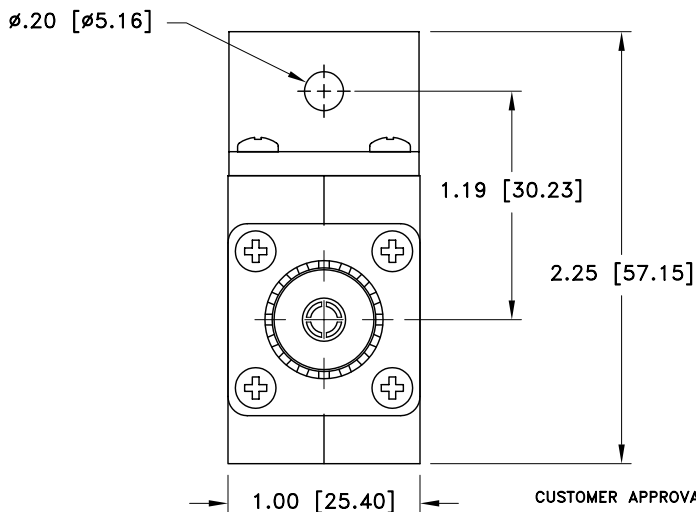
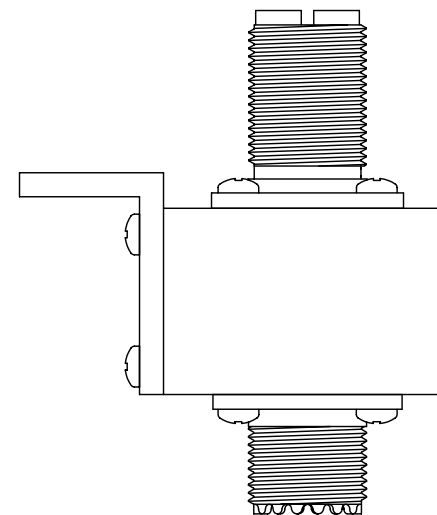
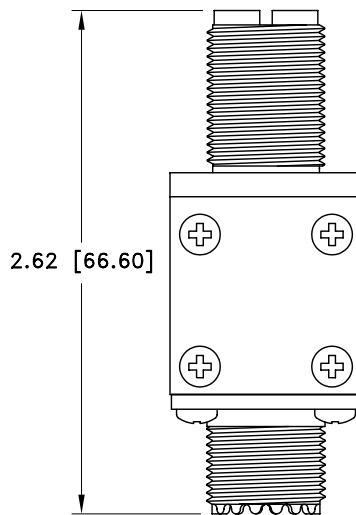
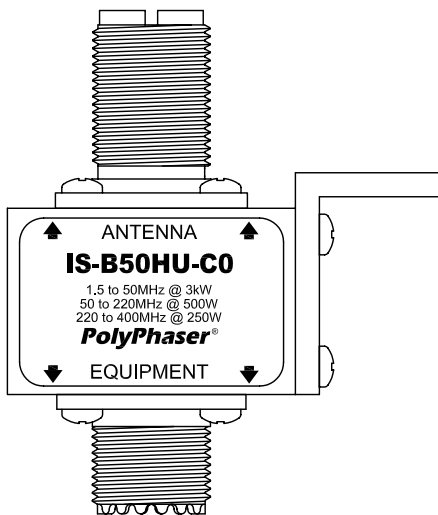

CUSTOMER APPROVAL: _____ DATE: _____

ALL DIMENSIONS SHOWN ABOVE ARE FOR REFERENCE ONLY.

MAXIMUM CHARACTERISTICS
APPLICATION: BULKHEAD MOUNT
FREQUENCY RANGE: 1.5MHz TO 400MHz
SURGE: 50kA IEC 1000-4-5 8/20μs WAVEFORM 500J
TURN-ON: 1200Vdc ±20% 7ns FOR 2kV/ns
VSWR: ≤1.2:1 @ 1.5MHz TO 400MHz
INSERTION LOSS: <0.1dB OVER FREQUENCY RANGE
MAX POWER: HF 3kW, VHF 500W, UHF 250W
THROUGHPUT ENERGY: <20mJ TYPICAL
OPERATING TEMPERATURE: -45°C TO +50°C
STORAGE TEMPERATURE: -45°C TO +85°C
RELATIVE HUMIDITY: 90% AT 40°C
VIBRATION: 1G AT 5Hz TO 100Hz

DRAFTER C. GASPARINI	DATE 06/18/98	PolyPhaser® P.O. BOX 9000, MINDEN, NV 89423-9000 (775) 782-2511 FAX (775) 782-4476 DWG NO/PART NO/DESCRIPTION IS-B50HU-C0 CUSTOMER PRINT			
MECH ENGINEER R. DUNNING	DATE 06/29/98				
ELEC ENGINEER K. BARTEL	DATE 06/24/98				
MARKETING - - - -	DATE - - - -				
QUALITY DEPT R. MATHEUS	DATE 06/24/98	CAGE CODE 61114	FILE NAME -C1	SCALE 1/1	SHEET 1 OF 1