

ALL DESIGN, OPERATIVE AND PROCESS DATA PERTAINING TO THE ARTICLE SHOWN ON THIS SHEET IS THE PROPERTY OF POLYPHASER CORPORATION. THE INFORMATION IS NOT TO BE COPIED, REPRODUCED, REVEALED TO OR APPROPRIATED BY OTHERS WITHOUT THE EXPRESS WRITTEN CONSENT OF POLYPHASER CORPORATION.

REVISIONS				
REV LTR	DATE	ENG	MKTG	Q.A.
A	01/11/01 _{IB}	KCB	PH	RM
B	05/03/01 _{IB}	RCD	PH	RM

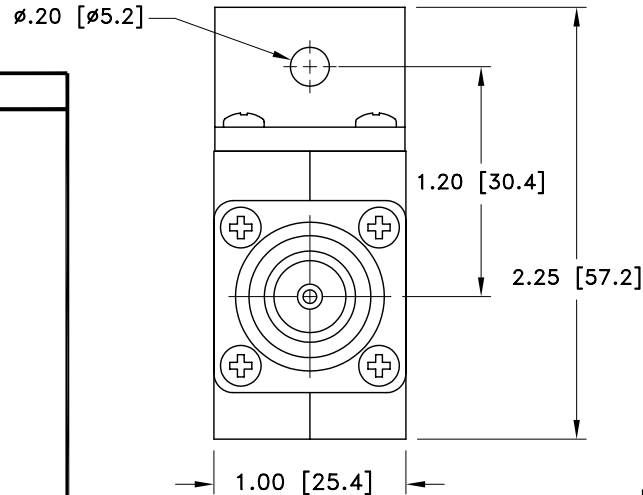
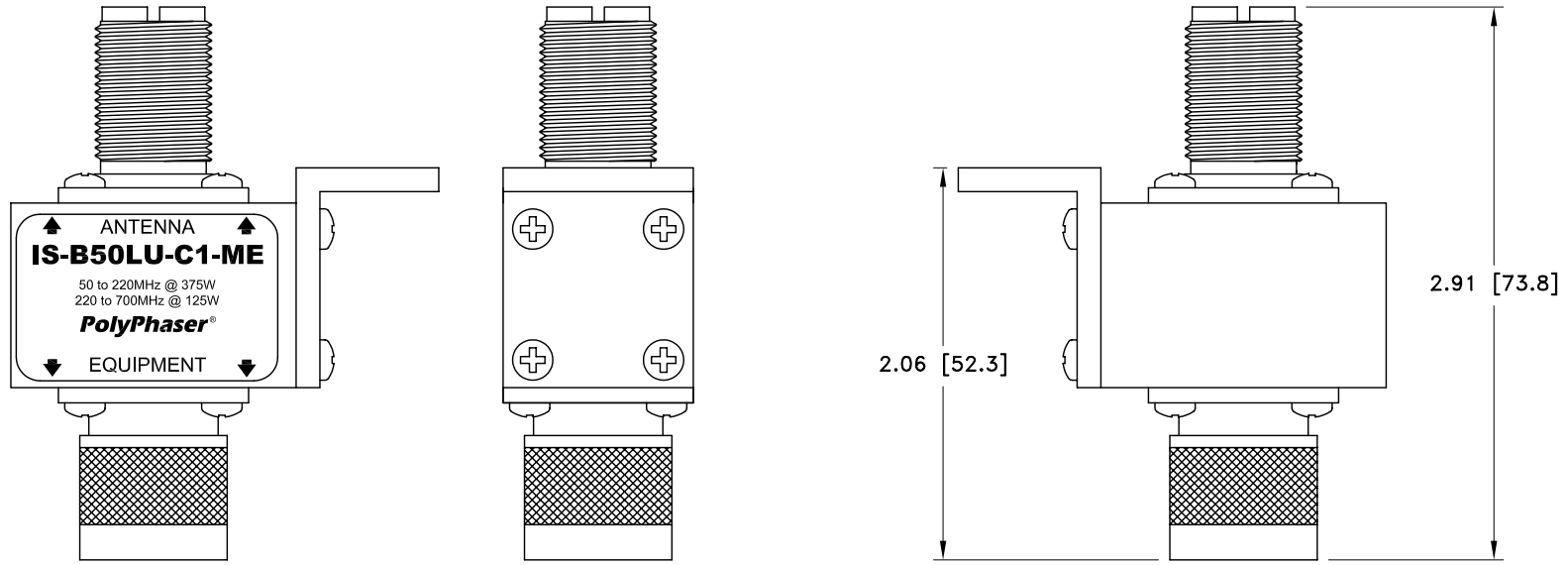

MAXIMUM CHARACTERISTICS
APPLICATION: BULKHEAD MOUNT
SURGE: 50kA IEC 1000-4-5 8/20μs WAVEFORM
FREQUENCY RANGE: 50MHz TO 700MHz
VSWR: ≤1.2:1 @ 50MHz TO 700MHz
INSERTION LOSS: ≤0.1dB OVER FREQUENCY RANGE
MAX POWER: VHF 375W UHF 125W
THROUGHPUT ENERGY: ≤600μJ FOR 3kA, 8/20μs WAVE FORM
TEMPERATURE: -45°C TO +85°C STORAGE/OPERATING +50°C
VIBRATION: 1G @ 5Hz TO 100Hz

CUSTOMER APPROVAL: _____ DATE: _____

ALL DIMENSIONS SHOWN ABOVE ARE FOR REFERENCE ONLY.

DRAFTER S. HALL	DATE 09/28/99	PolyPhaser® P.O. BOX 9000, MINDEN, NV 89423-9000 (775) 782-2511 FAX (775) 782-4476 DWG NO/PART NO/DESCRIPTION IS-B50LU-C1-ME CUSTOMER PRINT			
MECH ENGINEER P. SKROTZKI	DATE 04/04/00				
ELEC ENGINEER K. BARTEL	DATE 03/30/00				
MARKETING P. HEEREN	DATE 03/30/00				
QUALITY DEPT R. MATHEUS	DATE 03/31/00	CAGE CODE 61114	FILE NAME -C1	SCALE 1/1	SHEET 1 OF 1