

ALL DESIGN, OPERATIVE AND PROCESS DATA PERTAINING TO THE ARTICLE SHOWN ON THIS SHEET IS THE PROPERTY OF POLYPHASER CORPORATION. THE INFORMATION IS NOT TO BE COPIED, REPRODUCED, REVEALED TO OR APPROPRIATED BY OTHERS WITHOUT THE EXPRESS WRITTEN CONSENT OF POLYPHASER CORPORATION.

REVISIONS

REV LTR	DATE	ENG	MKTG	Q.A.
C	12/07/04 SH	KCB	SD	LJ

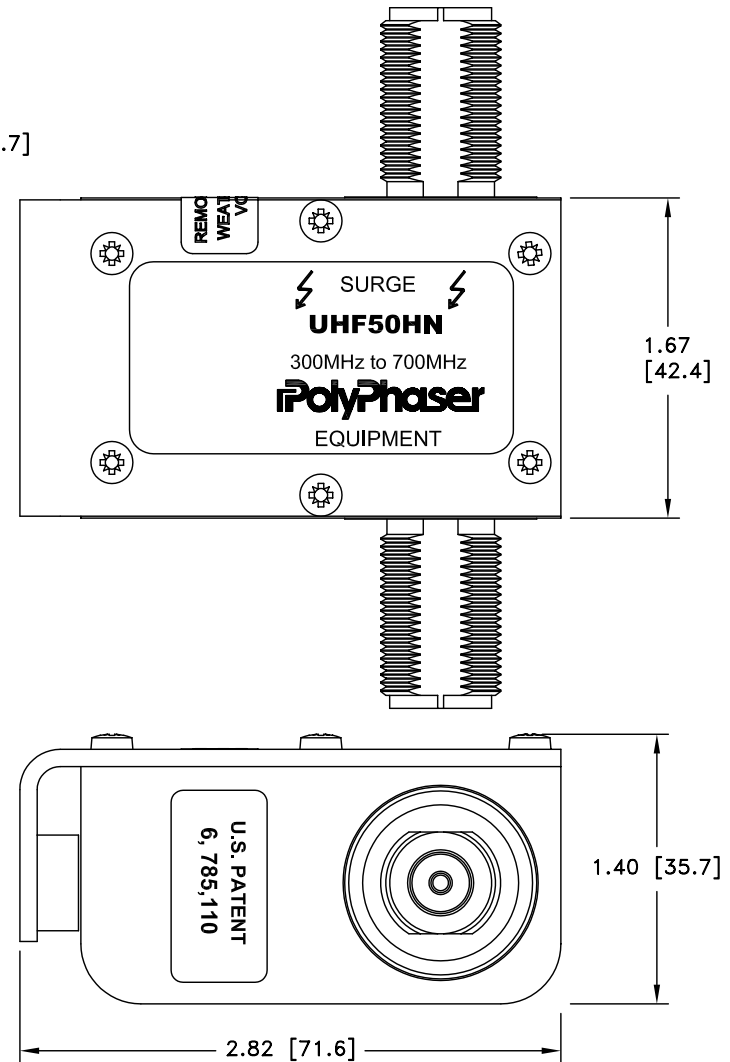
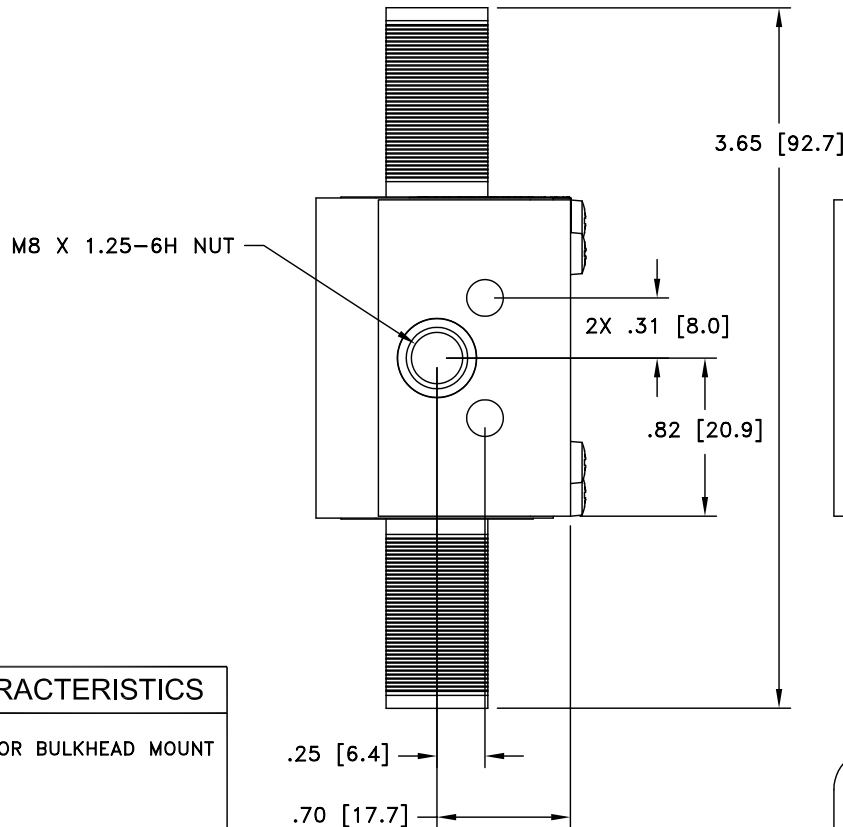

MAXIMUM CHARACTERISTICS

APPLICATION:  
 WEATHERIZED, FLANGE OR BULKHEAD MOUNT  
 FREQUENCY RANGE:  
 300MHz TO 700MHz  
 VSWR:  
 ≤1.1:1 OVER FREQUENCY RANGE  
 INSERTION LOSS:  
 ≤0.1dB OVER FREQUENCY RANGE  
 POWER:  
 750W RMS AVERAGE  
 MAX. SURGE:  
 20kA IEC 61000-4-5 8/20μs WAVEFORM  
 THROUGHPUT ENERGY:  
 ≤500nJ FOR 3kA, 8/20μs WAVEFORM  
 RELATIVE HUMIDITY:  
 TO 95%  
 ENVIRONMENTAL:  
 MEETS IEC 60529 IPC67  
 MEETS BELLCORE #TA-NWT-000487  
 PROCEDURE 4.11, WIND DRIVEN (120MPH)  
 RAIN INTRUSION TEST.  
 TEMPERATURE:  
 -50°C TO +85°C STORAGE/OPERATING

CUSTOMER APPROVAL: \_\_\_\_\_ DATE: \_\_\_\_\_

ALL DIMENSIONS SHOWN ABOVE ARE FOR REFERENCE ONLY.

DRAFTER S. HALL	DATE 06/06/03	 P.O. BOX 9000 MINDEN, NV 89423 TEL: 775-782-2511 FAX: 775-782-4476 DWG NO/PART NO/DESCRIPTION UHF50HN CUSTOMER PRINT	
MECH ENGINEER R. DUNNING	DATE 06/26/03		
ELEC ENGINEER N. TOPCU	DATE 06/16/03		
MARKETING S. DOTTER	DATE 06/20/03		
QUALITY DEPT L. JACQUES	DATE 06/16/03		
CAGE CODE 61114	FILE NAME -C1	SCALE 1/1	SHEET 1 OF 1