



MAGNETIC-LATCHING TO-5 RELAYS ESTABLISHED RELIABILITY MILITARY SPDT



SERIES	RELAY TYPE
421	SPDT basic relay
421D	SPDT relay with internal diode for coil transient suppression
421DD	SPDT relay with polarity reversal protection and coil transient suppression diode

DESCRIPTION

The magnetic-latching TO-5 relay, originally conceived and developed by Teledyne, has become one of the industry standards for low-level switching from dry circuit to 0.5 ampere. Designed for high-density PC board mounting, its small size and low coil power dissipation make the 421 relay one of the most versatile ultraminiature relays available.

The following unique construction features and manufacturing techniques provide excellent resistance to environmental extremes and overall high reliability:

The 421 feature:

- All welded construction.
- Unique uni-frame design providing high magnetic efficiency and mechanical rigidity.
- High force/mass ratios for resistance to shock and vibration.
- Advanced cleaning techniques provide maximum assurance of internal cleanliness.
- Precious metal alloy contacts material with gold plating assures excellent high current and dry circuit switching capabilities.

The Series 421D and 421DD utilize discrete silicon diodes for coil suppression and polarity reversal protection.

By virtue of its inherently low intercontact capacitance and contact circuit losses, the 421 relay has proven to be an excellent ultraminiature RF switch for frequency ranges well into the UHF spectrum. A typical RF application for this TO-5 relay is in handheld radio transceivers, wherein the combined features of good RF performance, small size, low coil power dissipation and high reliability make it a preferred method of transmit-receive switching.

The Series 421 magnetic-latching relays are ideally suited for applications where coil power dissipation must be minimized. The relays can be operated with a short duration pulse. After the contacts have transferred, no external holding power is required.

The magnetic latching feature of the Series 421 provides a "memory" capability, since the relays will not reset upon removal of coil power.

Principle of Operation:

Energizing Coil B produces a magnetic field opposing the magnetic field of the permanent magnet in Circuit B. As the net holding force decreases, the attractive force in the air gap of Circuit A, which also results from the magnetic field of the permanent magnet, becomes great enough to break the armature free of Core B, and snap it into a closed position against Core A. The armature remains in this position upon removal of power from Coil B, but will snap back into position B upon energizing Coil A. Since operation depends upon cancellation of a magnetic field, it is necessary to apply the correct polarity to the relay coils as indicated on the relay schematic.

When latching relays are installed in equipment, the latch and reset coils should not be pulsed simultaneously. Coils should not be pulsed with less than rated coil voltage and the pulse width should be a minimum of three times the specified operate time of the relay. If these conditions are not followed, it is possible for the relay to be in the magnetic neutral position. Should this happen, however, pulsing one coil or the other, as prescribed, will bring the relay back into proper operating condition.

ENVIRONMENTAL AND PHYSICAL SPECIFICATIONS

Temperature (Ambient)	-65°C to +125°C
Vibration (Note 1)	30 g's to 3000 Hz
Shock (Note 1)	75 g's, 6ms half sine
Acceleration	50 g's
Enclosure	Hermetically sealed
Weight	0.159 oz. (4.5g) max.
Reflow Temperature	260°C max. temp. 1 min. max

INTERNAL CONSTRUCTION

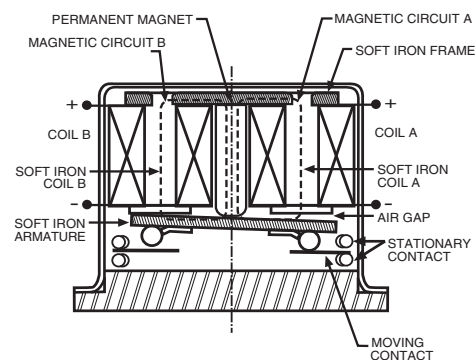

PART NUMBERING SYSTEM (Notes 5 & 6)

T²R Established Reliability Relays

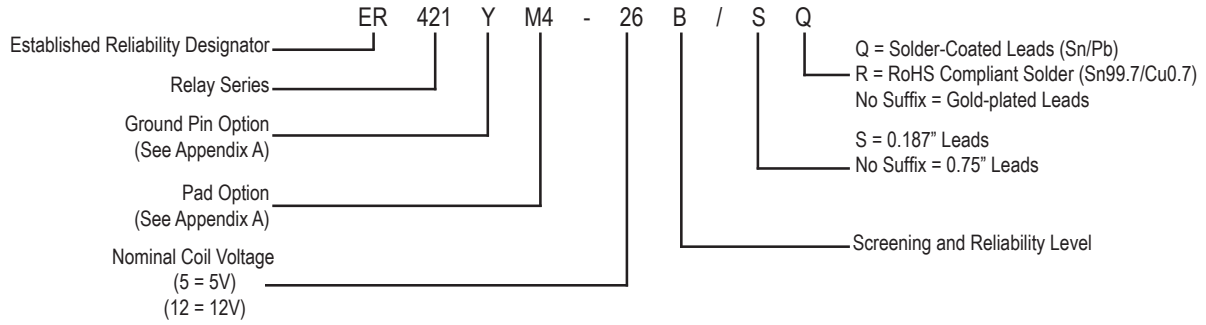

Military Qualified (JAN) Relays

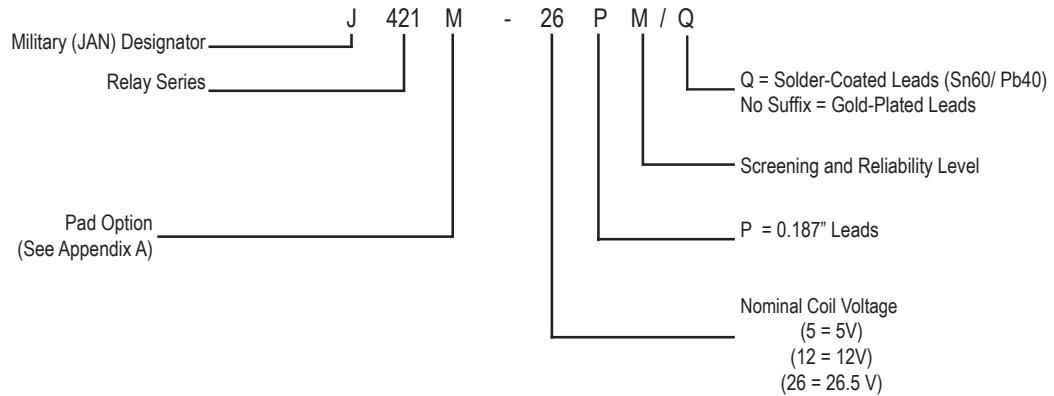

GENERAL ELECTRICAL SPECIFICATIONS (-65°C to +125°C unless otherwise noted) (Notes 2 & 3)

Contact Arrangement	1 Form C (SPDT)
Rated Duty	Continuous
Contact Resistance	0.125 ohm max. before life; 0.225 ohm max. after life at 1A/28V _{dc} (measured 1/8" from header)
Contact Load Rating (DC)	Resistive: 0.5 A / 28 V _{dc} Inductive: 200 mA / 28 V _{dc} (320mH) Lamp: 100 mA / 28 V _{dc} (320mH) Low level: 10 to 50 μA @ 10 to 50 mV
Contact Load Rating (AC)	Resistive: 250 mA / 115Vac, 60 and 400 Hz (Case not grounded) 100 mA / 115 Vac, 60 and 400 Hz (Case grounded)
Contact Life Ratings	10,000,000 cycles (typical) at low level 1,000,000 cycles (typical) at 0.5 A / 28 V _{dc} resistive 100,000 cycles min. at all other loads specified above
Contact Overload Rating	1 A / 28 V _{dc} Resistive (100 cycles min.)
Coil Operating Power	290 mW typical at nominal rated voltage
Contact Carry Rating	Contact Factory
Operate Time	1.5 ms max. at nominal rated coil voltage
Minimum Operate Pulse	4.5 ms width @ rated voltage
Contact Bounce	1.5 ms max
Intercontact Capacitance	0.4 pf typical
Insulation Resistance	10,000 MΩ min. between mutually isolated terminals
Dielectric Strength	500 V _{rms} / 60 Hz @ atmospheric pressure 125 V _{rms} / 60 Hz @ 70,000 ft
Negative Coil Transient (V_{dc}) 421D, 421DD	1.0 V _{dc} Max.
Diode P.I.V. (V_{dc}) 421D, 421DD	100 V _{dc} Min.

DETAILED ELECTRICAL SPECIFICATIONS (-65°C to +125°C unless otherwise noted) (Note 3)

BASE PART NUMBERS (421, 421D, 421DD)		421-5 421D-5 421DD-5	421-12 421D-12 421DD-12	421-26 421D-26 421DD-26
Coil Voltage	Nom.	5.0	12.0	26.5
	Max.	6.0	16.0	32.0
Coil Resistance (Ohms ±10% @25°C)	421, 421D	61	500	2000
	421DD (Note 4)	48	500	2000
Coil Current (432DD) (mA_{dc}@25°C)	Min.	78.0	19.6	11.2
	Max.	111.8	26.7	15.2
Set & Reset Voltage (V_{dc}, Max)	421	3.5	9.0	18.0
	421D	3.7	9.0	18.0
	421DD	4.5	10.0	19.0

NOTES:

- Relay contacts will exhibit no chatter in excess of 10 μsec or transfer in excess of 1 μsec.
- "Typical" characteristics are based on available data and are best estimates. No on-going verification tests are performed.
- Unless otherwise specified, parameters are initial values.
- For reference only. For 421DD, Coil resistance not directly measurable at relay terminals due to internal series diode.
- Unless otherwise specified, relays will be supplied with either gold-plated.
- The slash and characters appearing after the slash are not marked on the relay.

**SERIES 421
OUTLINE DIMENSIONS**

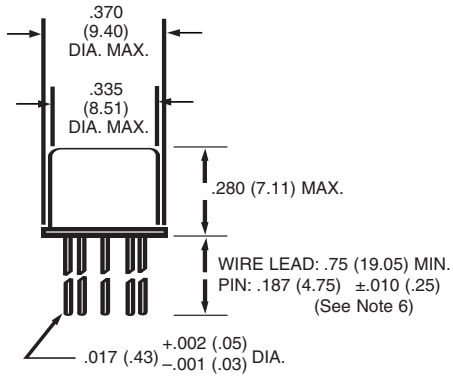

**TERMINAL LOCATIONS AND PIN NUMBERING (REF. ONLY)
(Viewed from Terminals)**

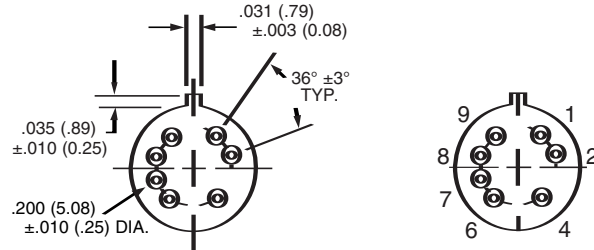

DIMENSIONS ARE SHOWN IN INCHES (MILLIMETERS)

SCHEMATIC DIAGRAMS

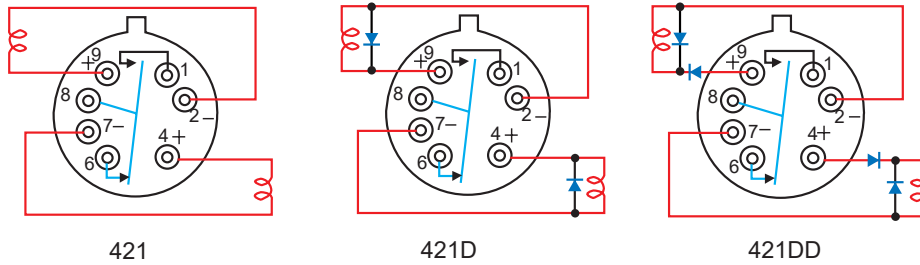

PERFORMANCE CURVES (Note 2)

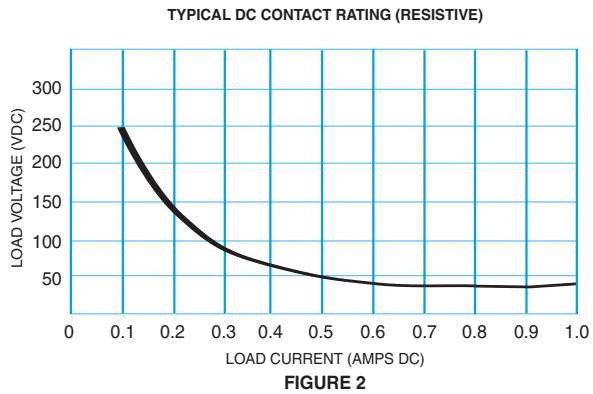
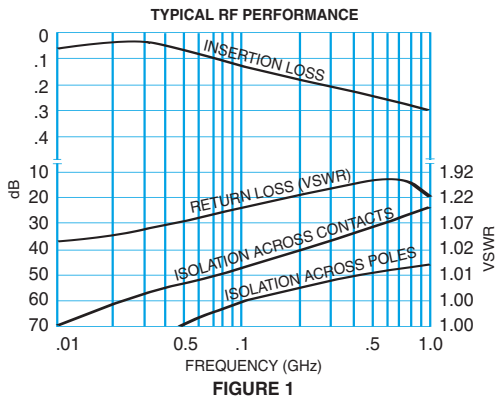

APPENDIX A : Spreader Pads

Pad designation and bottom view dimensions

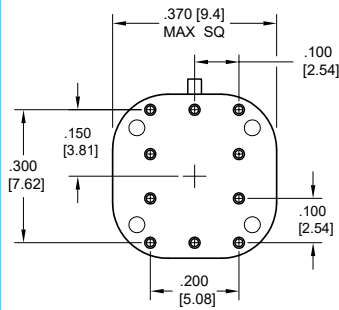

Height

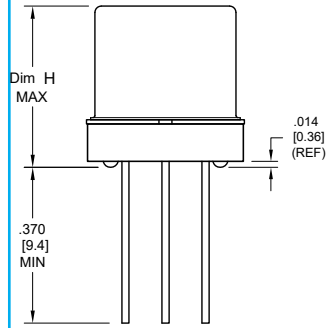

For use with the following:

J421, ER421

Dim. H Max.

.398 (10.11)

Notes:

1. Spreader pad material: Diallyl Phthalate.
2. To specify an "M" spreader pad, refer to the mounting variants portion of the part number example in the applicable datasheet.
3. Dimensions are in inches (mm).
4. Unless otherwise specified, tolerance is $\pm .010$ " (0.25 mm).
- 5/. Add 25 m Ω to the contact resistance shown in the datasheet.
- 6/. Add .01 oz. (0.25 g) to the weight of the relay assembly shown in the datasheet.