

Part Number	Description
LD24KKW	Solid State Relay with Short Circuit Protection and Trip Status
LD24KKY	Solid State Relay with Short Circuit Protection and Trip Status

The Y suffix denotes parameters tested to MIL-PRF-28750 Specifications.

The W suffix denotes parameters tested to Teledyne Specifications.

ELECTRICAL SPECIFICATIONS

(-55°C to +125°C UNLESS OTHERWISE NOTED)

INPUT (CONTROL) SPECIFICATIONS

When used in 2 terminal configuration (TTL or direct control)

	Min	Typ	Max	Units
Input Current @ $V_{IN} = 5 V_{DC}$ (See Fig 2)			35	mA
Turn-Off Voltage (Guaranteed Off)			1.5	V_{DC}
Turn-On Voltage (Guaranteed On)	4.2			V_{DC}
Reverse Voltage Protection			-32	V_{DC}
Input Supply Range (See Note 1, 7)	4.2		16	V_{DC}

INPUT (CONTROL) SPECIFICATIONS

When used in 3 terminal configuration (CMOS or open collector TTL)

	Min	Typ	Max	Units
Control Current			500	μA_{DC}
$V_{CONTROL} = 5 V_{DC}$			2.0	$m A_{DC}$
$V_{CONTROL} = 18 V_{DC}$ (See Note 7)			18	V_{DC}
Control Voltage Range (See Note 7)	0			V_{DC}
Bias Supply Voltage (See Note 1, 7)	4.2		16	V_{DC}
Bias Supply Current @ $V_{BIAS} = 5 V_{DC}$			35	mA
Control Turn-Off Voltage (Guaranteed Off)	3.2			V_{DC}
Control Turn-On Voltage (Guaranteed On)		0.3		V_{DC}

OUTPUT (LOAD) SPECIFICATIONS

(See Note 2)

	Min	Typ	Max	Units
Continuous Load Current (See Fig. 3)			5.0	A_{DC}
Leakage Current @ $V_{LOAD} = 270 V_{DC}$			0.35	mA
Output Voltage Drop			0.6	V_{DC}
Continuous Operating Load Voltage			270	V_{DC}
Transient Blocking Voltage @ 25°C (See Note 3)			500	V_{pk}
ON Resistance R_{ds} (on) (See Fig 4)			0.12	Ω
Turn-On Time (See Fig. 5)			0.12	mS
Turn-Off Time (See Fig. 5)			1.0	mS
Electrical System Spike (See Note 7)			±600	V_{DC}

ENVIRONMENTAL SPECIFICATIONS

	Min	Max	Units
Temperature Range			
Operating	-55	+125	°C
Storage	-55	+125	°C
Vibration, 100 g (See Note 7)	10	3000	Hz
Constant Acceleration		5000	g
Shock, 0.5 ms pulse (See Note 7)		1500	g
Dielectric Strength @ 25°C	1000		V_{AC}
Insulation Resistance @ 500 Vdc @ 25°C	10^9		Ω

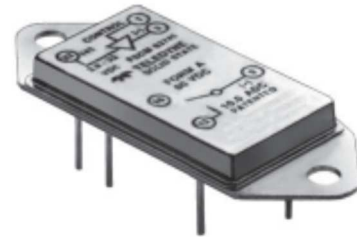

FEATURES

- Short-circuit/current overload protection
- Trip status output
- TTL and CMOS compatible control
- Low ON resistance power FET output
- Fast switching speed
- Meets 270 V_{DC} system requirements of MIL-STD-704
- Optical isolation
- Low profile hermetic package
- Built and tested to the requirements of MIL-PRF-28750
- Available in 'W' and 'Y' screening levels

DESCRIPTION

This solid-state relay utilizes the latest technology to provide a low ON resistance and an optically isolated output. The control (input) and load (output) are optically isolated to protect input logic circuits from voltage and current transients which can occur on the output supply.

The optical isolation also provides a full floating output, thus allowing the load to be connected to either output terminal. The control circuit is buffered to enable the relay to be driven directly from standard CMOS or open collector TTL logic circuits.

Short-circuit and current overload protection features provide complete protection for both the relay and the system wiring. This feature not only provides protection, should a short or overload occur while the relay is on, but will also provide protection should the relay be switched on into a short. In either case, the relay will sense the short-circuit condition, then block it indefinitely until the short is removed and the unit is reset by cycling the input control. The trip status returns a logic 0 (low) if the output trips off and a logic 1 (high) when the output is in a normal mode (on or off).

Thermal Dissipation Properties	Min	Max	Units
Output Junction Temperature @ $I_{LOAD} = I_{MAX RATED}$ (See Note 7)		+145	°C
Maximum Junction Temperature (T_J Max) (See Note 7)		+150	°C
Thermal Resistance Junction to Ambient (θ_{JA}) (See Note 7)	30		°C/W
Thermal Resistance Junction to Case (θ_{JC}) (See Note 7)	5		°C/W

ELECTRICAL SPECIFICATIONS, CONT.

(-55°C to +125°C UNLESS OTHERWISE NOTED)

STATUS OUTPUT TRUTH TABLE (LD24KK)

Output (Switch) State	Status Output Level
Tripped	Low ($V_{SO} \leq 0.4 V_{DC}$)
Not Tripped	High ($V_{SO} = V_{STATUS}$)

(SEE Note 6)	Min	Typ	Max	Units
Status Blocking Voltage (50 μ A _{dc})			30	V _{DC}
Status Supply Voltage (See Fig. 8)	1		18	V _{DC}
Status Leakage Current			2	μ A _{DC}
Status (sink) Current ($V_{SO} < 0.4 V_{dc}$)			12	mA _{DC}
Status Turn-On Time (See Fig. 6) (See Note 7)			1.0	mS
Status Turn-Off Time (See Fig. 6) (See Note 7)			1.0	mS

SHORT CIRCUIT PROTECTION SPECIFICATIONS

(@ TA = 25°C)	Min	Typ	Max	Units
Time to Trip (Turning relay ON into a short)			150	μ s
Time to Trip (Shorting load while relay is ON)			100	μ s

NOTES:

- Control input is compatible with CMOS or open collector TTL (with pull up resistor). For bias voltages above 6V, a series resistor is required. Use the standard resistor value equal to or less than the value found in Figure 6.
- The rated input voltage is 5V for all tests unless otherwise specified.
- Transient blocking voltage test is performed @ 25°C per MIL-PRF-28750.
- Overload testing to the requirements of MIL-PRF-28750 is constrained to the limits imposed by the short circuit protection characteristics as defined in this specification. System series inductance for "shorted-load" mode of operation should be 30 μ H MAXIMUM. Repetitive turn-on rate into a shorted load is not allowed.
- A status pull up resistor is required for proper operation of the status output. Determine the current (I_{SO}) required by the status interface. Calculate the current (I_S) through the status resistor such that the sink current through the status output is 12 mA. Select the status resistor such that it does not allow more than 12 mA to flow through the status output.
$$R_{STATUS} = (V_{STATUS} - 0.4V) / 12mA$$
- Inductive loads should be diode suppressed. Input transitions should be < 20 μ s duration and the input drive should be a bounceless contact type.
- Parameter Guaranteed by Design, but not tested.

BLOCK DIAGRAM

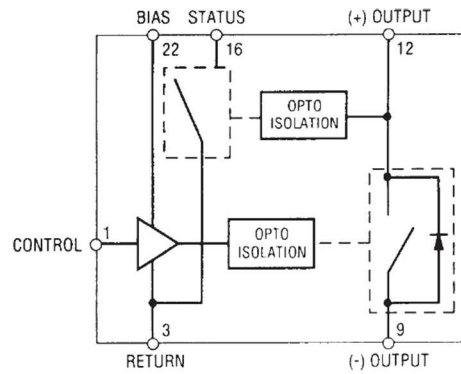

WITH STATUS

Figure 1

MECHANICAL SPECIFICATION

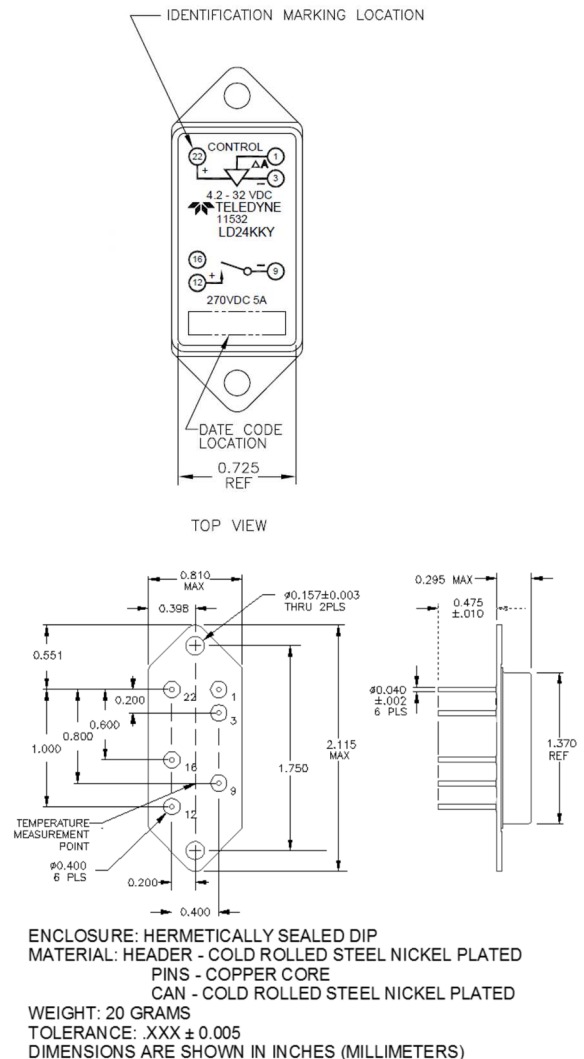

BIAS (INPUT) CURRENT vs BIAS (INPUT) VOLTAGE

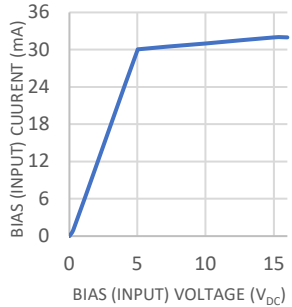

FIGURE 2
(See Note 1)

LOAD CURRENT DERATING CURVE

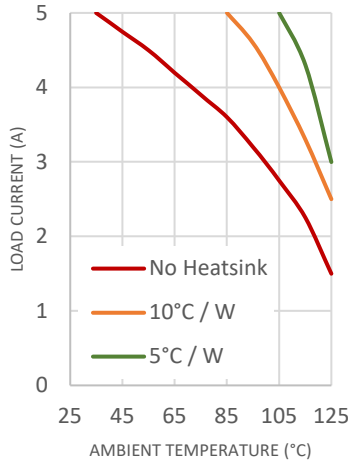
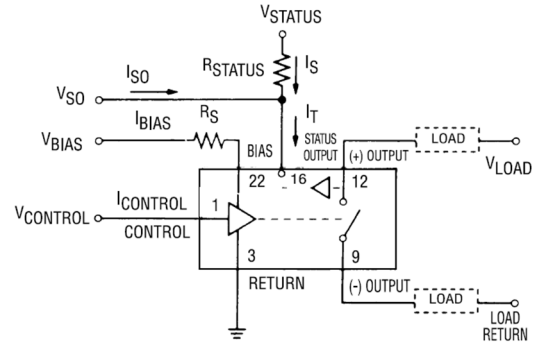

FIGURE 3

WIRING CONFIGURATIONS



3 TERMINAL INPUT WITH STATUS (See Note 5)

NORMALIZED ON RESISTANCE vs JUNCTION TEMPERATURE

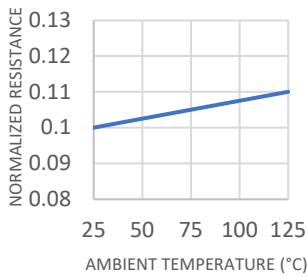

FIGURE 4

OUTPUT TURN-ON AND TURN-OFF TIMING

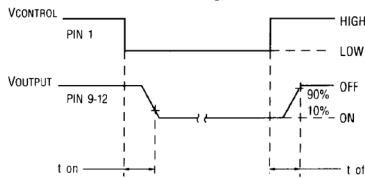
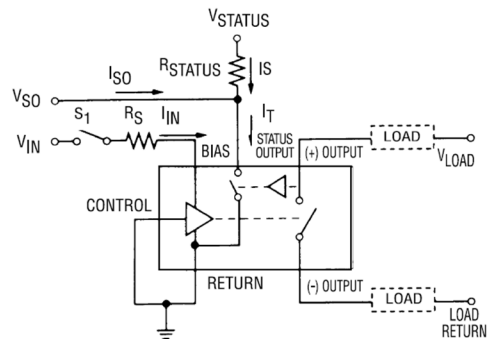

FIGURE 5



2 TERMINAL INPUT (DIRECT DRIVE) WITH STATUS

SERIES LINE BIAS RESISTOR vs BIAS VOLTAGE

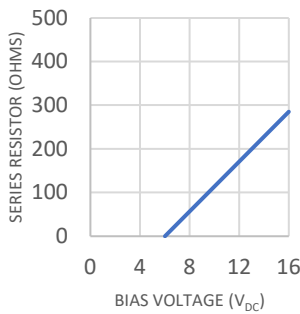

FIGURE 6

OVERLOAD CURRENT vs TIME TO TRIP (TYPICAL)

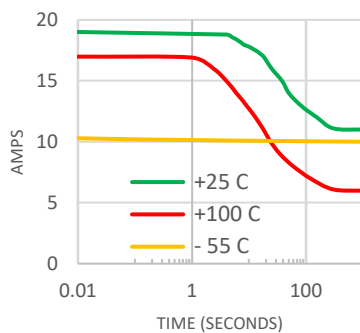
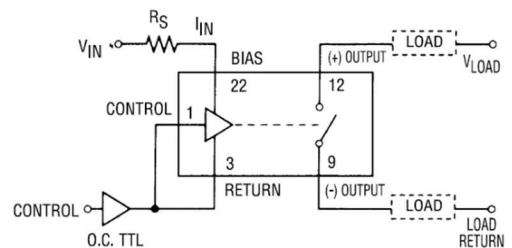

FIGURE 7



2 TERMINAL INPUT (OPEN COLLECTOR TTL DRIVE)

FIGURE 8

DATA PRESENTED IS TYPICAL - FOR REFERENCE ONLY

For application assistance contact relays@teledyne.com or (800) 284-7007